

Superdense Teleportation and Quantum Key Distribution for Space Applications

Trent Graham, Christopher Zeitler, Joseph Chapman,
Paul Kwiat
Department of Physics
University of Illinois at Urbana-Champaign
Urbana, USA
tgraham2@illinois.edu

Hamid Javadi
Submillimeter Wave Advanced Technology Group
Jet Propulsion Laboratory,
California Institute of Technology
Pasadena, USA

Herbert Bernstein
Institute for Science & Interdisciplinary Studies &
School of Natural Sciences
Hampshire College
Amherst, USA

Abstract—The transfer of quantum information over long distances has long been a goal of quantum information science and is required for many important quantum communication and computing protocols. When these channels are lossy and noisy, it is often impossible to directly transmit quantum states between two distant parties. We use a new technique called superdense teleportation to communicate quantum information deterministically with greatly reduced resources, simplified measurements, and decreased classical communication cost. These advantages make this technique ideal for communicating quantum information for space applications. We are currently implementing an superdense teleportation lab demonstration, using photons hyperentangled in polarization and temporal mode to communicate a special set of two-qubit, single-photon states between two remote parties. A slight modification of the system readily allows it to be used to implement quantum cryptography as well. We investigate the possibility of implementation from an Earth's orbit to ground. We will discuss our current experimental progress and the design challenges facing a practical demonstration of satellite-to-Earth SDT.

Keywords—Quantum entanglement; Superdense teleportation; quantum communication

I. INTRODUCTION

Developments in the field of quantum communication science over the past two decades have offered increased channel capacity [1] and provably secure communication [2]. Additionally, techniques for the remote transfer of quantum states (an important resource for other quantum information protocols, e.g., distributed quantum computing) have been developed [3,4] and are a key component to realizing a quantum network [5]. However, such protocols require reliable distribution of entangled states—quantum states which exhibit a strong nonlocal correlation—between remote parties. Unfortunately, such states cannot currently be stored

for long periods of time (as would be needed for large scale quantum repeaters) and cannot be amplified without introducing error [6] and thus can be very difficult to distribute over large distances using conventional communication techniques. Despite current limitations, some quantum communication protocols have already been demonstrated over long-distances in terrestrial experiments. Notably, quantum teleportation (a remote quantum state transfer protocol), has been performed over a distance of 143 km between La Palma and Tenerife of the Canary Islands [7] and 97 km between the cities of Gangcha and Guanjing [8]. Such free-space terrestrial quantum communication implementations are constrained by line-of-sight and turbulence limitations. Alternatively, developing a satellite-based quantum network is potentially the most practical way of establishing reliable quantum communication between very distant parties on Earth. While the establishment of such a network is beyond current technology, many initial steps are currently feasible. In particular, the distribution of quantum entanglement between a satellite and a terrestrial target would demonstrate a key ingredient for a future world-wide quantum network. Such a demonstration would enable several other quantum communication protocols to be implemented.

In this manuscript, we discuss different photonic degrees of freedom and how they can be used to encode a hyperentangled state—simultaneously entangled in multiple degrees of freedom—which can be distributed over a long-distance free-space link. We then describe how they can help implement an entanglement-based quantum state communication technique known as superdense teleportation [9,10] and a four-dimensional variant of a well-known quantum key distribution protocol known as BB84 [2]. We will then present a table-top demonstration of superdense teleportation and discuss the future directions for adapting

this prototype for an International Space Station (ISS)-to-Earth implementation building on our previous studies [11].

II. METHODS

A. Photonic qubits for satellite communication

The production of high-fidelity quantum states is the first step of any entanglement-based quantum communication protocol. These states can be encoded in different physical degrees of freedom of photons, e.g., polarization, spatial distribution, arrival time, etc. However, care must be taken that the quantum channel does not disrupt these properties. For example, while the spatial modes of photons have been successfully used to greatly increase the capacity of a relatively short classical communication channel [12], atmospheric turbulence will disrupt the phase coherence of spatial qubits transmitted over long-distance free-space channels, and high beam divergence will also prevent high-order spatial-modes from being collected efficiently. For our quantum communication implementation, we have chosen to use polarization and photon arrival time to encode quantum information.

Photon polarization appears to be an ideal photonic degree of freedom for long-range satellite-to-ground quantum communication. Since photon polarization belongs to the SU(2) symmetry group, it provides a natural qubit (quantum bit) structure, and polarization is easily manipulated and measured by using birefringent elements and polarizers. Additionally, since there are no strongly birefringent elements or polarization-dependent scattering elements in the atmosphere, a quantum channel between an orbiting satellite and a terrestrial telescope will not disrupt a polarization qubit. However, while the atmosphere itself will not be disruptive, geometric effects due to changes in the beam pointing as the satellite passes overhead can cause polarization rotation [11]. Similarly, the mirrors used in beam-pointing systems can have an angle-dependent birefringent effect. Both effects must be compensated to effectively use polarization qubits in a satellite-to-Earth quantum communication protocol.

Photon arrival time can also be effectively used to transmit quantum information from a satellite to a terrestrial receiver. Since temporal mode is a continuous degree of freedom, it does not naturally form a two-dimensional qubit structure. However, by encoding quantum information on two discrete temporal modes, e. g., early and late time-bins, it is possible to encode a qubit on the photon arrival time ($\cos(\theta)|t_1\rangle + e^{i\phi}\sin(\theta)|t_2\rangle$). While arrival time can be used as an effective qubit, the relative motion between the satellite and telescope will result in a time-dependent path length. If the path length changes between the two temporal modes, the relative phase ϕ of the qubit state will vary proportionally to the path length difference of the two modes. This Doppler-induced phase shift will change as the satellite passes overhead [11], and must be compensated. By experimentally simulating this effect we have demonstrated that the Doppler-induced phase shift can be compensated using a beacon beam carrying interferometer phase information to stabilize the terrestrial interferometer; experimental details are listed in section III. Temporal quantum states can be

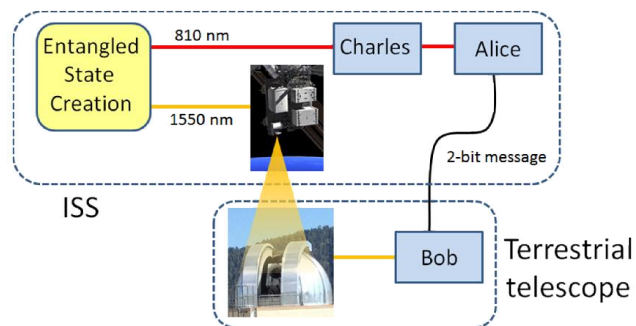

Fig. 1. A schematic of a satellite-to-ground implementation of superdense teleportation. The entangled state, Charles' phase rotations and Alice's measurement all take place on the satellite platform. The outcome of Alice's measurement and Bob's 1550-nm photon are then transmitted to the ground where it is collected by a terrestrial telescope. Bob can then correct his photon based on Alice's measurement.

characterized using an unbalanced interferometer; by measuring the photon arrival time on the output of this interferometer, the temporal mode is projected into an informationally complete set of states. Using this information, it is possible to reconstruct the quantum state. However, the different interferometer arm lengths can cause imperfect spatial mode overlap at the interferometer output. Turbulence will only exacerbate this problem increasing the transverse spatial frequency of the beam, causing it to diverge more quickly. Additionally, any change in the input beam momentum due to imperfect beam pointing will result in interferometer phase changes and imperfect spatial-mode overlap as well. This issue can be resolved by using a single-mode spatial filter on the output of the temporal mode analyzer; however, loss introduced by this filtering process will greatly reduce the signal strength. Alternately, by adding an imaging system to the temporal-mode analyzer, the spatial mode overlap on the analyzer output can be recovered [13].

B. Superdense teleportation

One of the most practical ways to test a quantum channel is to use it to perform a useful quantum protocol. An appropriate test protocol must be considered. Despite being the most practically realized type of quantum communication protocol, quantum key distribution does not require entanglement to implement, in contrast to many advanced quantum applications, such as a quantum network, which do require distribution of entangled states. For this reason, demonstrating a quantum communication protocol which also requires entanglement would be an important step to implementing many more advanced quantum communication protocols beyond simple quantum cryptography. On the other hand, quantum superdense coding [1] and quantum teleportation [3] both require entanglement, but both of these techniques would be very challenging to implement between a satellite and a terrestrial telescope. Superdense coding requires either an indefinitely long quantum memory (not feasible with current technology) or a double use of the very lossy quantum channel between satellite and ground observer. Quantum teleportation is much more feasible than superdense coding and has already been used in long range demonstrations; however, it requires more than one photon pair to implement. The additional photon pair required by

this technique would drastically reduce the rate of successful teleportation events, thereby greatly reducing the experimental signal-to-noise ratio. These aspects, in addition to the fact that the orbital motion of a satellite will greatly limit collection duration, make a satellite-based implementation of quantum teleportation very challenging.

Quantum superdense teleportation [9], is a quantum communication protocol that requires entanglement, but is much easier to implement over long distances than superdense coding and quantum teleportation (See Fig. 1). Superdense teleportation is an entanglement-based quantum state communication protocol, which is designed to deterministically transmits a quantum state from the sender (Alice) to a receiver (Bob) with less classical communication and experimental resources than are required by traditional quantum teleportation and remote state preparation. In this protocol a bipartite maximally entangled state of the form:

$$|\Psi^n\rangle = \frac{1}{\sqrt{n}}(|00\rangle + |11\rangle + \dots + |(n-1)(n-1)\rangle) \quad (1)$$

is created. Half of this bipartite state is sent to a state chooser (Charles) and the other half to a receiver (Bob). Charles chooses what state he wishes to send from a class of equimodular states. This class of states, also known as an equatorial qudit, is of the form $\frac{1}{\sqrt{n}}(|0\rangle + e^{i\varphi_1}|1\rangle + \dots + e^{i\varphi_{n-1}}|n-1\rangle)$ and has a toroidal topology which allows them to be transmitted more efficiently than general qudit states [10]. Charles then performs a unitary transformation on his photon based on the particular equimodular state that he has chosen transforming the total state to:

$$|\Theta^n\rangle = \frac{1}{\sqrt{n}}(|00\rangle + e^{i\theta_1}|11\rangle + \dots + e^{i\theta_{n-1}}|(n-1)(n-1)\rangle). \quad (2)$$

After adding these phase shifts Charles sends the photon to the state sender (Alice). Alice then performs a measurement in a basis which is mutually unbiased to the basis in which Charles applied phases (i.e., each state in the measurement basis has a $1/\sqrt{n}$ overlap with each state in Charles' basis). Alice sends the result of her measurement to Bob (one of n possible outcomes), who then performs a corrective unitary transformation on his photon based on the message that he receives from Alice. This transformation rotates Bob's photon to the state that Charles originally chose.

To most effectively show the advantage of superdense teleportation over traditional entanglement-based quantum state communication protocols, equimodular states with two or more state parameters should be transmitted. However, such an implementation requires a state that is maximally entangled in at least three dimensions. We previously implemented a proof of principle demonstration of this technique, using photons that were hyperentangled in polarization and orbital angular momentum [10]. However, as mentioned above, such spatial-mode qubits are not well suited for long-distance quantum communications. By implementing superdense teleportation with photons hyperentangled in polarization and arrival time, we will

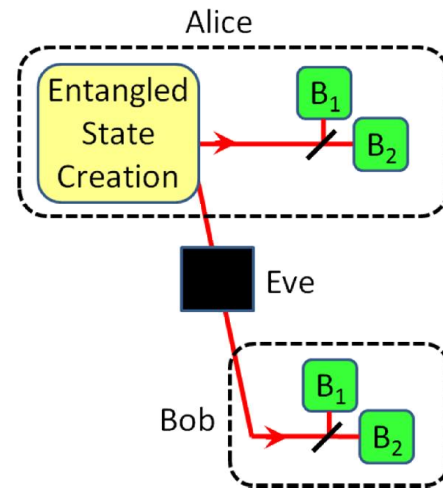

Fig. 2. Schematic of a basic quantum key distribution setup. By using beamsplitters to randomly select a basis in which to measure their respective photons, Alice and Bob are each able to build up a string of random numbers. They then publically announce in which bases they measured in. By keeping only events in which they measured in the same basis, Alice and Bob generate a shared random key. Error correction and privacy amplification must then be used to ensure that Alice's and Bob's key strings match and are private.

provide a laboratory demonstration to inform an implementation of superdense teleportation from a satellite.

C. Quantum key distribution

One of the primary reasons to demonstrate a quantum communication protocol that requires entanglement is that many other quantum protocols can be implemented using a similar experimental setup. In particular, even though implementing quantum key distribution does not require entanglement, it can be readily demonstrated using almost identical experimental resources to those required for our proposed implementation of superdense teleportation. Using the same source of photons hyperentangled in polarization and arrival time, a four-dimensional entangled variant of the BB84 can be implemented. In this protocol, two parties (Alice and Bob) want to generate a shared secret key which they can use as a one-time-pad for encoding cryptographic messages [14]. However, any communication between Alice and Bob can, in principle, be intercepted by an eavesdropper (Eve). If Eve learns any information about Alice's and Bob's secret key, she can then gain some information about the encrypted message. If Alice can generate entangled states of the form given by Equation 1 and send half of each state to Bob, they can use the nonlocal correlations of entanglement to generate a shared cryptographic key that is provably secret from Eve (see Fig. 2). To do this, both Alice and Bob randomly measure their half of an entangled state in either basis B_1 or basis B_2 , where B_1 and B_2 are mutually unbiased to each other. After both Alice and Bob complete their measurement they announce over a public channel which of the two bases they selected for their measurement, but not the specific measurement results. No matter which basis was selected, the individual outcomes for both Alice and Bob will be random. However, if Alice and Bob both chose the same measurement basis (i.e., if the both chose B_1 or they both chose B_2) their measurement results will be perfectly

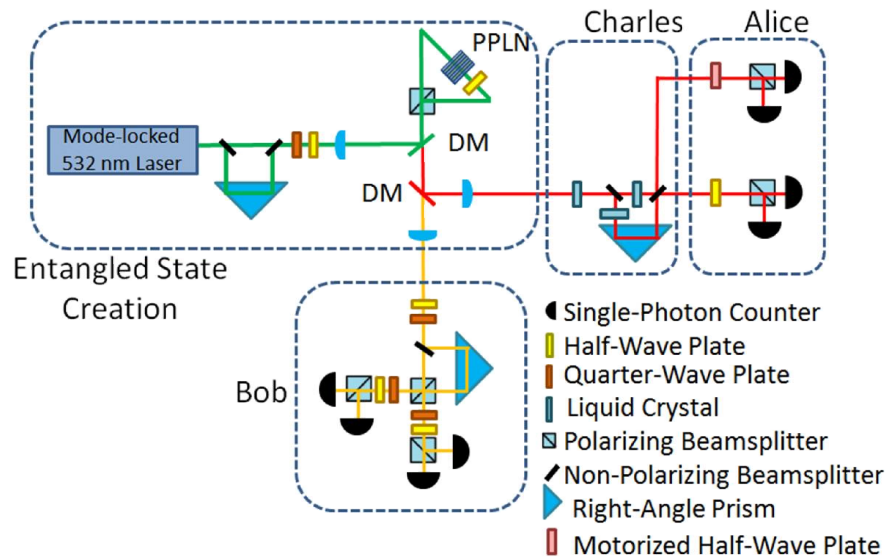

Fig. 3. Our experimental implementation of superdense teleportation using polarization and temporal mode. We use non-degenerate type-0 spontaneous parametric downconversion in periodically-poled lithium niobate crystals (PPLN) to create a state hyperentangled in polarization and temporal mode. The entangled photon pairs are separated using dichroic mirrors (DM). Charles probabilistically separates the two temporal modes and applies phases using liquid crystals. After the output of Charles' interferometer, Alice then performs her measurement using polarizing beamsplitters and single-photon counters. Bob performs an informationally complete set of measurements to characterize the state of his photon. By detecting in coincidence with Alice, Bob can determine how successful Alice's measurement was at heralding the target state. This same experimental setup can also be used to implement quantum key distribution. By rotating one half wave plate and changing her temporal filter to look in the t_1, t_2 basis, Alice can measure in two mutually unbiased bases. Bob can use very similar techniques to perform measurements on his photons.

correlated. On the other hand, if Alice and Bob chose different bases, their results will be uncorrelated and they discard this event. By repeating this experiment many times, Alice and Bob build up a shared random key.

Before Alice and Bob can use their key to encode messages, they must ensure that Eve does not have any part of the secret key. In order for Eve to gain information about Alice and Bob's key, she would need to perform measurements on the photons that Alice transmits to Bob. While there are many strategies that Eve could use to obtain information about Alice and Bob's secret key [15], all of them will introduce errors into Bob's measurement outcomes part of the time, since Eve has no way of knowing Alice's and Bob's measurement bases. Thus, Alice and Bob can detect whether Eve was making measurements on Bob's photons by sacrificing part of their shared secret key to check for errors. In principle, if there is no eavesdropper, Alice and Bob's secret key will be error-free. However, experimental imperfections will introduce error in the secret key. Because Alice and Bob use key errors to assess whether or not an Eve is gaining information about the secret key, any type of error must be treated as if it was introduced by Eve. After the error-rate of the key is determined, Alice and Bob fix the errors by exchanging some of the information of their long, compromised key to create a shorter, secure key by using well established methods for error correction and privacy amplification [15].

While many traditional quantum key distribution techniques employ maximally entangled qubits as the quantum state that Alice and Bob use to generate their shared randomness, there are advantages to using the larger

entangled state provided by hyperentangled photons [16]. Most notably, if the photons that Alice and Bob share are hyperentangled in polarization and temporal mode as described in the previous section, Alice and Bob obtain two bits of "raw" secret key every time they measure their photons in the same basis, instead of one bit as obtained using maximally entangled qubits.

III. RESULTS

A. Entangled Photon Source

As stated in Section II, our experiments require a source of photons that are hyperentangled in polarization and temporal mode. We create these photon states using the process of nondegenerate Type 0 phase-matched spontaneous parametric downconversion in a nonlinear crystal. Specifically, we use a magnesium-oxide doped

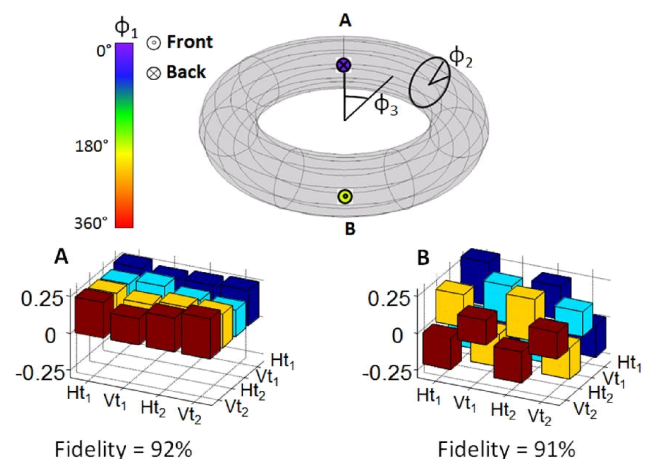

Fig. 4. Initial reconstructed density matrices. For these measurements, we only used one of Alice's measurement output (a_i) in coincidence with Bob measurements to reconstruct the two-qubit single photon state that Alice's measurement heralded on Bob's photon. The fidelity of the reconstructed output states was well above the 44% threshold that is possible using only separable states.

periodically poled lithium niobate (PPLN) crystal to downconvert a 532-nm horizontally polarized photon into two lower energy, horizontally polarized photons (one at 810 nm and one at 1550 nm). Polarization entanglement is generated by placing the PPLN crystal in a polarizing Sagnac interferometer with an achromatic half-wave plate (see Fig. 3) [17]. In this configuration, a downconversion event in the clockwise (counter-clockwise) path of the interferometer creates two vertically (horizontally) polarized photons at the output of the interferometer, resulting in a maximally entangled polarization state.

Temporal-mode entanglement is generated by pumping the PPLN crystals with two coherent temporal modes. These two modes are generated by sending laser pulses from our 532-nm mode-locked laser into an unbalanced interferometer (see Fig. 3). This interferometer splits each laser pulse into two coherent temporal modes, which are separated by the path-length difference of the interferometer arms. Both daughter photons in the downconversion process are created in the same temporal mode, so a temporal-mode entangled photon state is created by simply pumping the PPLN crystal with the two temporal modes originating from the unbalanced interferometer [18]. By combining this technique with the method for creating polarization entanglement described above, we create a pair of photons that are

hyperentangled in polarization and temporal mode. The two photons are then separated from each other using a dichroic mirror.

For reliable implementation of quantum protocols, it is important to assess the quality of the entangled states generated. This characterization can be performed using quantum state tomography [19]. In this process, an informationally complete set of measurements are made on many copies of the quantum state, building up a relative probability distribution for outcomes of measurements made on the quantum state. We performed these measurements on the polarization of our photon pairs by using wave plates and polarizers to measure each photon in the following over-complete set of measurements:

$$\{(H, V, D, A, R, L)_{Alice} \otimes (H, V, D, A, R, L)_{Bob}\}. \quad (3)$$

We employed maximum likelihood techniques to estimate the density matrix of the polarization state of our photon pairs. To estimate the state of our photons' temporal mode, we performed a partial tomography, measuring relative probability of the $|t_1 t_1\rangle$ and $|t_2 t_2\rangle$ terms of the quantum state and then measuring the coincidence visibility in the $(|t_1 \pm t_2\rangle) \otimes (|t_1 \pm t_2\rangle)$ basis. Even though this set of

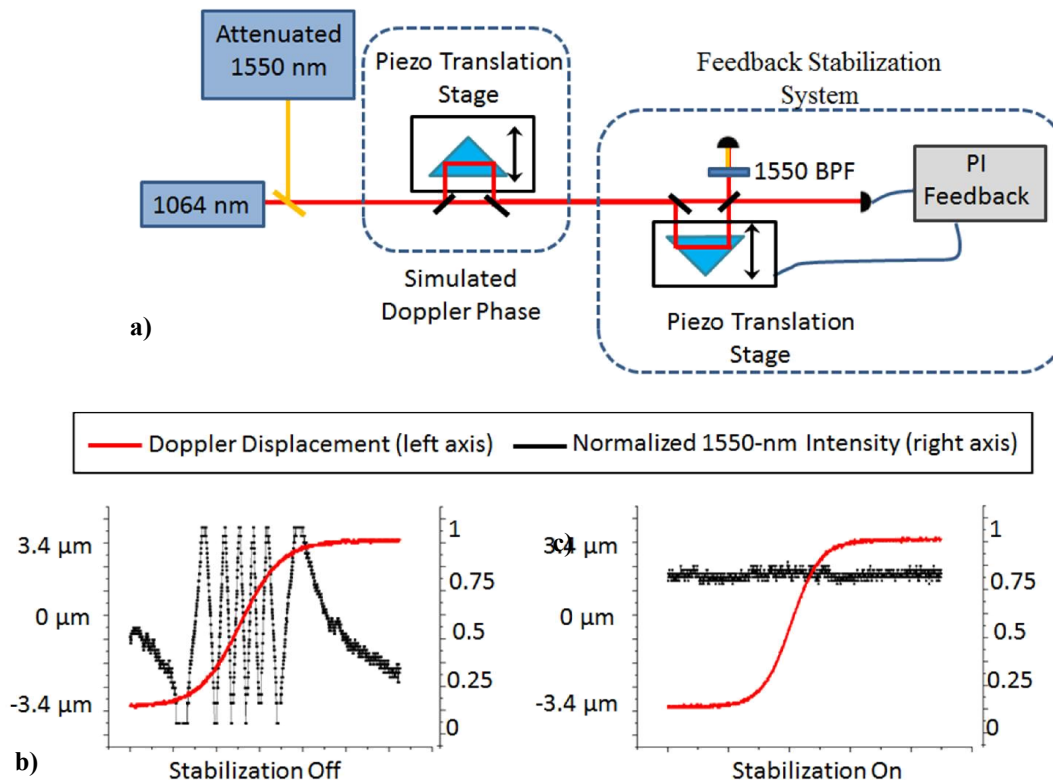

Fig. 5. **a)** Our prototype system for correcting the Doppler-induced phase shift cause by the relative motion of a space platform with respect to a terrestrial observer. An attenuated 1550-nm laser is combined with a strong 1064-nm beacon beam. The Doppler-induced phase shift was then simulated using an unbalanced interferometer and a piezo stage programmed to trace out the Doppler shift (but at about half the calculated displacement magnitude since the piezo stage range was limited). The two beams were then sent into another interferometer, and the interference fringe of the 1064-nm beacon was used to lock the phases of the two interferometers. A band-pass filter (BPF) is used to filter out the 1064-nm beacon light from the 1550-nm signal **b)** The 1550-nm interference pattern with the beacon stabilization deactivated. **c)** The 1550-nm interference pattern with the beacon stabilization activated, showing a standard deviation of $<2^\circ$.

measurements is not informationally complete, we can use it, along with the assumption that both photons of each pair are created in the same temporal mode, to estimate the temporal mode of our photon pair state. Using these techniques we estimate our polarization state fidelity to be 95% and the temporal-mode state fidelity to be 98%.

B. Superdense Teleportation

Once the quality of the two-photon hyperentangled state is measured, we can use these photons to implement superdense teleportation. In our implementation, the 1550-nm photon was sent to Bob and the 810-nm photon was sent to Charles (See Fig. 4b). For this proof-of-principle experiment, the two temporal modes of Charles' photons were probabilistically separated using a non-polarizing beamsplitter. Charles then applied phases to the polarization state of two different temporal modes using liquid crystals resulting in the target state, $\frac{1}{2}(|Ht_1\rangle + e^{i\varphi_1}|Vt_1\rangle + e^{i\varphi_2}|Ht_2\rangle + e^{i\varphi_3}|Vt_2\rangle)$. The photon was sent to Alice who made measurements in the following basis:

$$\begin{aligned} |a^\pm\rangle &\equiv \frac{1}{\sqrt{2}}|D\rangle \otimes (|t_1\rangle \pm |t_2\rangle) \\ |b^\pm\rangle &\equiv \frac{1}{\sqrt{2}}|A\rangle \otimes (|t_1\rangle \pm |t_2\rangle). \end{aligned} \quad (4)$$

If we write the total state of Alice and Bob's photon pair in terms of Alice's measurement, we have:

$$\begin{aligned} &\frac{1}{4}[|a^+\rangle(|Ht_1\rangle + e^{i\varphi_1}|Vt_1\rangle + e^{i\varphi_2}|Ht_2\rangle + e^{i\varphi_3}|Vt_2\rangle) + \\ &|a^-\rangle(|Ht_1\rangle + e^{i\varphi_1}|Vt_1\rangle - e^{i\varphi_2}|Ht_2\rangle - e^{i\varphi_3}|Vt_2\rangle) + \\ &|b^+\rangle(|Ht_1\rangle - e^{i\varphi_1}|Vt_1\rangle + e^{i\varphi_2}|Ht_2\rangle - e^{i\varphi_3}|Vt_2\rangle) + \\ &|b^-\rangle(|Ht_1\rangle - e^{i\varphi_1}|Vt_1\rangle - e^{i\varphi_2}|Ht_2\rangle + e^{i\varphi_3}|Vt_2\rangle)]. \end{aligned} \quad (5)$$

We see it is possible for Bob to correct his state with a unitary transformation based on the outcome of Alice's measurement, essentially telling him which of the 4 terms need a π phase shift. For our initial experiments, we did not measure every state in Alice's basis, but instead simply measured $|a^+\rangle$. Then in coincidence with Alice's measurement, Bob performed a complete polarization and temporal mode tomography on his photon. By performing this state reconstruction, we were able to determine which state Alice's measurement heralded on Bob's side (see Fig. 4). We see that these initial measurements show an average quantum state fidelity of 91%, which is over twice the classical limit of 44% [10]. We are currently adding the rest of Alice's measurement outcomes and plan to implement feed-forward transformations for Bob, so we can perform a full demonstration of superdense teleportation.

C. Modifications for Quantum Key Distribution

Very little modification needs to be made to the experimental configuration described in the previous section to implement quantum key distribution. In particular, the entangled source and Bob's measurement capabilities are identical for superdense teleportation and 4-dimensional quantum key distribution. However, we need to allow Alice the capability of switching between two mutually unbiased bases for her measurements (the state chooser Charles is combined with Alice's measurement in this protocol). With the addition of one motorized half-wave plate (see Fig. 3), Alice and Bob can both make measurements in two mutually unbiased bases, and Alice and Bob can then use the quantum key distribution protocol described above in the Methods Section to generate a shared string of secret random bits.

D. Doppler Compensation Studies

As discussed above, transmitting temporal-mode qubits between parties in relative motion can induce changing phase shifts between the two temporal modes used to encode the qubit. To adapt our experimental setup for a satellite-to-Earth quantum communication protocol, this phase shift must be compensated. We have simulated this phase shift on a classical input state (an attenuated 1550-nm pulsed laser source) (see Fig. 5a). We demonstrated that it is possible to correct this shift by stabilizing an unbalanced interferometer (used as a temporal-mode analyzer) with respect to the output of a 1064-nm "beacon beam" (see Fig. 5b and 5c). This technique not only corrects temporal qubit phase changes due to the relative motion of the satellite, but also corrects shifts due to relative drift of the two interferometers, allowing for reliable temporal qubit encoding and analysis.

IV. CONCLUSIONS

Satellite-to-Earth quantum communication is an important step in building up a global quantum network. In this manuscript we discuss an experimental design that would allow us to perform both superdense teleportation and quantum key distribution, and describe our laboratory implementation. We examined some of the technical issues facing a satellite-based implementation and examined possible solutions for addressing challenges that it faces. Based on our results to date, we believe that a space-to-Earth quantum link should be attainable.

ACKNOWLEDGMENT

This work was supported by NASA NIAC Program and NASA Grant No. NNX13AP35A. The research carried out at the Jet Propulsion Laboratory, California Institute of Technology, was under a contract with the National Aeronautics and Space Administration.

REFERENCES

- [1] C. H. Bennett and S. J. Wiesner, "Communication via one- and two-particle operators on Einstein-Podolsky-Rosen states," *Physical Review Letters*, vol. 69, no. 20, pp. 2881, 1992.
- [2] C. H. Bennett and G. Brassard, "Quantum cryptography; public key distribution and coin tossing." International Conference on Computers, Systems, and Signal Processing, Bangalore. pp. 175-179, 1984.
- [3] C. H. Bennett, et al., "Teleporting an unknown quantum state via dual classical and Einstein-Podolsky-Rosen channels," *Physical Review Letters*, vol. 70, no. 13, pp. 1895, 1993.
- [4] C. H. Bennett, et al., "Remote state preparation," *Physical Review Letters*, vol. 87, no. 7, pp. 077902, 2001.
- [5] J. H. Kimble, "The quantum internet," *Nature*, vol. 453, no. 7198, 1023-1030, 2008.
- [6] W. K. Wootters, and W. H. Zurek, "A single quantum cannot be cloned," *Nature*, vol. 299, no. 5886, pp. 802-803, 1982.
- [7] X.-S. Ma, et al., "Quantum teleportation over 143 kilometres using active feed-forward." *Nature*, vol. 489, no. 7415, pp. 269-273, 2012.
- [8] J. Yin, et al., "Quantum teleportation and entanglement distribution over 100-kilometre free-space channels." *Nature*, vol. 488, no. 7410, pp. 185-188, 2012.
- [9] H. Bernstein, "Superdense quantum teleportation," *Quantum Information Processing*, vol. 5, no. 6, pp. 451, 2006; B. Zeng and P. Zhang, "Remote-state preparation in higher dimension and the parallelizable manifold S^{n-1} ," *Physical Review A*, vol. 65, no. 2, pp. 022316, 2002.
- [10] Graham, Trent M., Herbert J. Bernstein, Tzu-Chieh Wei, Marius Junge, and Paul G. Kwiat. "Superdense teleportation using hyperentangled photons." *Nature Communications* 6 (2015).
- [11] T. M. Graham, H. J. Bernstein, H. Javadi, B. J. Geldzahler, and P. G. Kwiat. "Superdense teleportation for space applications." SPIE Sensing Technology+ Applications, International Society for Optics and Photonics, pp. 912302-912302, 2014.
- [12] J. Wang, et al., "Terabit free-space data transmission employing orbital angular momentum multiplexing." *Nature Photonics*, vol. 6, no. 7, pp. 488-496, 2012.
- [13] J. Jin, et al., "Efficient time-bin qubit analyzer compatible with multimode optical channels." arXiv preprint arXiv:1509.07490 (2015).
- [14] N. Gisin, G. Ribordy, W. Tittel, and H. Zbinden, "Quantum cryptography." *Reviews of Modern Physics*, vol. 74, no. 1, pp. 145, 2002.
- [15] M. A. Nielsen and I. L. Chuang, *Quantum computation and quantum information*, Cambridge University Press, 2010.
- [16] I. Ali-Khan, C. J. Broadbent, and J. C. Howell, "Large-alphabet quantum key distribution using energy-time entangled bipartite states." *Physical Review Letters*, vol. 98, no. 6, pp. 060503, 2007.
- [17] M. Hentschel, H. Hübel, A. Poppe, and A. Zeilinger, "Three-color Sagnac source of polarization-entangled photon pairs." *Optics express*, vol. 17, no. 25, pp. 23153-23159, 2009.
- [18] J. Brendel, N. Gisin, W. Tittel, and H. Zbinden, "Pulsed energy-time entangled twin-photon source for quantum communication." *Physical Review Letters*, vol. 82, no. 12, pp. 2594, 1999.
- [19] D. F. V. James, P. G. Kwiat, W. J. Munro, and A. G. White, "Measurement of qubits." *Physical Review A*, vol. 64, no. 5, pp. 052312, 2001.