

Quantum process estimation via generic two-body correlationsM. Mohseni,^{1,2} A. T. Rezakhani,³ J. T. Barreiro,^{4,5} P. G. Kwiat,⁴ and A. Aspuru-Guzik²¹*Research Laboratory of Electronics, Massachusetts Institute of Technology, 77 Massachusetts Avenue, Cambridge, Massachusetts 02139, USA*²*Department of Chemistry and Chemical Biology, Harvard University, 12 Oxford Street, Cambridge, Massachusetts 02138, USA*³*Department of Chemistry and Center for Quantum Information Science and Technology, University of Southern California, Los Angeles, California 90089, USA*⁴*Department of Physics, University of Illinois at Urbana-Champaign, Urbana, Illinois 61801, USA*⁵*Institut für Experimentalphysik, Universität Innsbruck, Technikerstrasse 25/4, A-6020 Innsbruck, Austria*

(Received 17 June 2009; published 3 March 2010)

Performance of quantum process estimation is naturally limited by fundamental, random, and systematic imperfections of preparations and measurements. These imperfections may lead to considerable errors in the process reconstruction because standard data-analysis techniques usually presume ideal devices. Here, by utilizing generic auxiliary quantum or classical correlations, we provide a framework for the estimation of quantum dynamics via a single measurement apparatus. By construction, this approach can be applied to quantum tomography schemes with calibrated faulty-state generators and analyzers. Specifically, we present a generalization of the work begun by M. Mohseni and D. A. Lidar [Phys. Rev. Lett. **97**, 170501 (2006)] with an imperfect Bell-state analyzer. We demonstrate that for several physically relevant noisy preparations and measurements, classical correlations and a small data-processing overhead suffice to accomplish the full system identification. Furthermore, we provide the optimal input states whereby the error amplification due to inversion of the measurement data is minimal.

DOI: [10.1103/PhysRevA.81.032102](https://doi.org/10.1103/PhysRevA.81.032102)

PACS number(s): 03.65.Wj, 03.67.Pp

I. INTRODUCTION

Quantum measurement theory imposes fundamental limitations on the information extractable from a quantum system. Although the evolution of quantum systems can be described deterministically, the measurement operation always leads to nondeterministic outcomes. In order to obtain the desired accuracy, measurement of a particular observable needs to be repeated over an ensemble of identical quantum systems. In addition, for systems with many degrees of freedom, one usually needs to measure a set of noncommuting observables corresponding to independent parameters of the system. Characterization of state or dynamics of a quantum system can be achieved by a family of methods known as quantum tomography [1,2]. In particular, quantum process tomography provides a general experimental procedure for estimating the dynamics of a system that has an unknown interaction with its embedding environment for discrete or continuous degrees of freedom [2–6]. In these methods, the full information is obtained by a complete set of experimental settings associated with the set of required input states and noncommuting measurements. In recent developments [3,4,7–10], it has been demonstrated that the minimum number of required experimental settings can be substantially reduced by using degrees of freedom of auxiliary quantum systems correlated with the system of interest.

In principle, it is possible to completely characterize a quantum device with a single experimental configuration including one input state and one measurement setting. This requires extra degrees of freedom of an auxiliary system in order to provide enough support in the Hilbert space for extracting relevant information about all independent parameters. A correlated input state of the combined system and ancilla is subjected to the unknown process, and a generalized measurement, or positive operator-valued measure (POVM), is performed at the output [11,12]. However, in order to realize such a

generalized measurement, one usually needs to effectively generate sufficient mixing or many-body interactions [13]. Despite some special cases, these interactions are not naturally available and/or controllable. Quantum simulation of such many-body interactions is in principle possible but generally requires an exponentially large number of single- and two-body interactions with respect to system's degrees of freedom [14]. An alternative method, circumventing the requirement for many-body interactions but allowing simultaneous noncommuting observables through a single measurement setting, is known as direct characterization of quantum dynamics (DCQD) [4,8]. The construction of the full information about the dynamical process is then possible via preparation of a set of mutually unbiased entangled input states over a subspace of the total Hilbert space of the principal system and an ancilla [8]. The DCQD approach was originally developed with the assumptions of ideal (i.e., error-free) quantum state preparation, measurement, and ancilla channels. However, in a realistic estimation process, because of decoherence, limited preparation and measurement accuracies, or other imperfections, certain errors may occur that hinder the overall process.

In this work, we introduce an experimental procedure for using generic two-body interactions to perform quantum process estimation on a subsystem of interest. We employ this approach to generalize the DCQD scheme to the cases in which the preparations and measurements are realized with known systematic faulty operations. We demonstrate that in some specific but physically motivated noise models, such as the generalized depolarizing channels, only classical correlations between system and ancilla suffice. Moreover, for these situations, the data-processing overhead is fairly small in comparison to the ideal DCQD. Given a noise model, one can find the optimal input states by minimizing the errors incurred through the inversion of experimental data. Thus, we provide

the optimal input states for reducing the inversion errors in the noiseless DCQD scheme.

The structure of the article is as follows. In Sec. II, we set the framework for process tomography schemes where faulty Bell-state analyzers occur, emphasizing the DCQD approach. Next, in Sec. III, we demonstrate the applicability of our framework through some simple yet important examples of noise models. We conclude with a summary in Sec. IV.

II. CHARACTERIZATION OF QUANTUM PROCESSES WITH A FAULTY BELL-STATE ANALYZER

Let us consider a given quantum system composed of two correlated physical subsystems A and B . For a time duration Δt , the two subsystems are decoupled, thus experiencing different quantum processes, and then they interact with each other again. The task is to characterize the unknown quantum process acting on the subsystem of interest, A , assuming we have prior knowledge about the dynamics of subsystem B plus their initial and final correlations. Another similar scenario can also be envisioned. Given two controllable quantum systems A and B that are made to sufficiently interact before and after a time duration Δt , we wish to estimate the unknown dynamics acting on system A for such a time interval, assuming the dynamics of the ancilla system B and the interaction between two systems are known within certain accuracy.

Much progress has been made in creating and characterizing two-body correlations in a variety of physical systems and interactions, including nuclear magnetic resonance (NMR) systems interacting through an Ising Hamiltonian together with refocusing or dynamical decoupling techniques [15], atoms or molecules in cavity quantum electrodynamics (QED) [16], trapped ions interacting via the Jaynes-Cummings Hamiltonian driven by laser pulses and vibrational degrees of freedom [17], and photons correlated in one or many degrees of freedom, for example, generated by parametric-down conversion [18] or four-wave mixing [19]. Other approaches include spin-coupled quantum dots [20], superconducting qubits [21] controlled by external electric and/or magnetic fields, and chromophoric complexes coupled through Förster or Dexter interactions and monitored or controlled via ultrafast nonlinear spectroscopy [22]. However, in almost all of these systems, the entangled Bell-state preparations (BSPs) and Bell-state measurements (BSMs), which generically are the basic building blocks of quantum information processing, hardly achieve high fidelities; they will be imperfect at least at some level, limiting their use for tomography. Our goal is to determine the optimal states and measurement strategy that will minimize the deleterious effects of the nonidealities—assumed known—on process tomography.

We consider the cases in which we can simulate initial or final two-body correlations in these schemes by performing an ideal (generalized) BSP (or BSM) followed by a *known* faulty completely positive (CP) quantum map acting on all the systems involved. It should be noted that not all CP maps can be written as a concatenation of two other CP maps. In other words, there exist CP maps that are indivisible in the sense that, for such a map \mathcal{T} , there do not exist CP maps \mathcal{T}_1 and \mathcal{T}_2 such that $\mathcal{T} = \mathcal{T}_2\mathcal{T}_1$, where neither \mathcal{T}_1 or \mathcal{T}_2 are unitary [23].

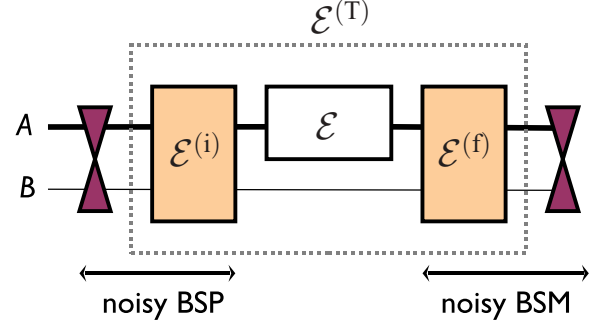

FIG. 1. (Color online) Schematic of a faulty DCQD, with imperfect or noisy BSP and BSM.

Nonetheless, all full-rank CP maps—in the sense of the Kraus representation [2]—are divisible.

Here, we also include quantum maps acting on system B during the preparation or measurement. This approach naturally provides a generalization of the DCQD scheme to the cases of faulty preparations, measurement, and ancilla channels where the noise is already known; see Fig. 1. For simplicity, in this work we concentrate only on one-qubit systems and the DCQD scheme (summarized in Table I). However, generalization of the framework is straightforward for other process estimation schemes and for DCQD on qudit systems with d being a power of a prime, according to the construction of Ref. [8].

Let us consider the qubit of interest A and the ancillary qubit B prepared in the maximally entangled state $|\Phi^+\rangle_{AB} = (|00\rangle + |11\rangle)_{AB}/\sqrt{2}$. We first apply a *known* quantum error map $\mathcal{E}^{(i)}$ to A and B : $\mathcal{E}^{(i)}(\rho) = \sum_{pqrs} \chi_{pqrs}^{(i)} \sigma_p^A \sigma_q^B \rho \sigma_r^B \sigma_s^A$, where $\rho = |\Phi^+\rangle\langle\Phi^+|$ and $\{\sigma_0 \equiv \mathbb{1}, \sigma_1, \sigma_2, \sigma_3\}$ are the identity and Pauli operator for a single qubit. Next, we apply the unknown quantum map \mathcal{E} to qubit A ; this is what we are trying to determine: $\mathcal{E}[\mathcal{E}^{(i)}(\rho)] = \sum_{mn} \chi_{mn} \sigma_m^A (\sum_{pqrs} \chi_{pqrs}^{(i)} \sigma_p^A \sigma_q^B \rho \sigma_r^B \sigma_s^A) \sigma_n^A$. Finally, we apply a *known* quantum error map before the BSM. Note that in this approach any error on the ancilla channel can be absorbed into either $\mathcal{E}^{(f)}$ or $\mathcal{E}^{(i)}$. The total map acting on the combined system AB is then $\mathcal{E}^{(T)} = \mathcal{E}^{(f)}\mathcal{E}\mathcal{E}^{(i)}$, given by

$$\mathcal{E}^{(T)}(\rho) = \sum_{mnp'q'r'r's's'} \chi_{mn} \chi_{pqrs}^{(i)} \chi_{p'q'r's'}^{(f)} \sigma_{p'}^A \sigma_{q'}^B \rho \sigma_{r'}^B \sigma_{s'}^A \times \rho \sigma_r^B \sigma_s^A \sigma_n^A \sigma_{r'}^B \sigma_{s'}^A,$$

TABLE I. Ideal direct characterization of single-qubit χ . Here $|\Phi_\alpha^+\rangle = \alpha|00\rangle + \beta|11\rangle$, $|\Phi_\alpha^+\rangle_{x(y)} = \alpha|++\rangle_{x(y)} + \beta|--\rangle_{x(y)}$, where $|\alpha| \neq |\beta| \neq 0$ and $\text{Im}(\bar{\alpha}\beta) \neq 0$ and where $\{|0\rangle, |1\rangle\}$, $\{|\pm\rangle_x\}$, and $\{|\pm\rangle_y\}$ are the eigenstates of the Pauli operators σ_z , σ_x , and σ_y . P_{Φ^+} is the projector on the Bell state $|\Phi^+\rangle$, and similarly for the other projectors; see Refs. [4,12]. Determination of optimal values of α and β is discussed in the text.

Input state	BSM	Output χ_{mn}
$ \Phi^+\rangle$	$P_{\Psi^\pm}, P_{\Phi^\pm}$	$\chi_{00}, \chi_{11}, \chi_{22}, \chi_{33}$
$ \Phi_\alpha^+\rangle$	$P_{\Phi^+} \pm P_{\Phi^-}, P_{\Psi^+} \pm P_{\Psi^-}$	χ_{03}, χ_{12}
$ \Phi_\alpha^+\rangle_x$	$P_{\Phi^+} \pm P_{\Psi^+}, P_{\Phi^-} \pm P_{\Psi^-}$	χ_{01}, χ_{23}
$ \Phi_\alpha^+\rangle_y$	$P_{\Phi^+} \pm P_{\Psi^-}, P_{\Phi^-} \pm P_{\Psi^+}$	χ_{02}, χ_{13}

where the parameters $\chi_{pqrs}^{(i)}$ and $\chi_{p'q'r's'}^{(f)}$ are known (from calibration of the operational or systematic errors in the preparation and measurement devices). By defining $\omega_{mnp's'} = (-1)^{(\delta_{m0}-1)(\delta_{p'0}-1)\delta_{mp'}+(\delta_{n0}-1)(\delta_{s'0}-1)\delta_{ns'}}$ and $\tilde{\rho}_{mn} = \sum_{pp'qq'rr'ss'} \omega_{mnp's'} \chi_{pqrs}^{(i)} \chi_{p'q'r's'}^{(f)} \sigma_p^A \sigma_q^B \sigma_r^A \sigma_{s'}^B \rho \sigma_r^B \sigma_s^A \sigma_{r'}^B \sigma_{s'}^A$, we have

$$\mathcal{E}^{(T)}(\rho) = \sum_{mn} \chi_{mn} \sigma_m^A \tilde{\rho}_{mn} \sigma_n^A.$$

By construction, the parameters $\chi_{pqrs}^{(i)}$ and $\chi_{p'q'r's'}^{(f)}$ are all *a priori* known, as are the matrices $\tilde{\rho}_{mn}$, which are functions of $\chi^{(i)}$, $\chi^{(f)}$, and the initial state ρ . Therefore, in order to develop a generalized DCQD scheme for the systems with faulty BSP and BSM, we need to do it for a set of modified (input) states rather than a pure Bell-state-type input. Expanding $\tilde{\rho}_{mn}$ in the Bell basis yields

$$\tilde{\rho}_{mn} = \sum_{kk'} \lambda_{mn}^{kk'} P^{kk'},$$

where $\lambda_{mn}^{kk'} = \text{Tr}[P^{kk'} \tilde{\rho}_{mn}]$, $P^{kk'} = |B^k\rangle\langle B^{k'}|$, and $|B^k\rangle$ for $k = 0, 1, 2, 3$ corresponds to the Bell states $|\Phi^+\rangle$, $|\Psi^+\rangle$, $|\Psi^-\rangle$, and $|\Phi^-\rangle$, respectively, where $|\Phi^\pm\rangle = (|00\rangle \pm |11\rangle)/\sqrt{2}$, $|\Psi^\pm\rangle = (|01\rangle \pm |10\rangle)/\sqrt{2}$. (Henceforth throughout this manuscript, superscripts refer to the Bell-state basis and subscripts refer to the Pauli operator basis.) The $\lambda_{mn}^{kk'}$ s are known functions of $\omega_{mnp's'}$, $\chi^{(f)}$, $\chi^{(i)}$, and ρ . Therefore, the overall output state can be rewritten as follows:

$$\mathcal{E}^{(T)}(\rho) = \sum_{kk'mn} \lambda_{mn}^{kk'} \chi_{mn} \sigma_m^A P^{kk'} \sigma_n^A.$$

We now apply the standard DCQD data analysis to estimate the matrix elements of $\chi^{(T)}$ (representing $\mathcal{E}^{(T)}$). After performing a BSM, that is, measuring $\{P^{jj}\}_{j=0}^3$ on this state, we obtain the Bell state $|B^j\rangle$ with the probability

$$\text{Tr}[P^{jj} \mathcal{E}^{(T)}(\rho)] = \sum_{kk'mn} \Lambda_{kk',mn}^{(j)} \chi_{mn},$$

where $\Lambda_{kk',mn}^{(j)} = \lambda_{mn}^{kk'} \text{Tr}[P^{jj} \sigma_m^A P^{kk'} \sigma_n^A]$. While this expression can be made more compact by using Pauli identities, the current form is convenient for our purposes.

A similar set of equations for the standard DCQD inputs $\{\rho^{(i)}\}_{i=0}^3$ can also be written. We represent all of these equations in a compact vector form as

$$|\chi^{(T)}\rangle = \Lambda |\chi\rangle, \quad (1)$$

where the $\Lambda(\chi^{(i)}, \chi^{(f)}, \{\rho^{(i)}\})$ matrix contains full information about all faulty experimental conditions. Given $\chi^{(i)}$, $\chi^{(f)}$, and the standard DCQD inputs set $\{\rho^{(i)}\}$, one can calculate the Λ matrix. The standard DCQD experimental data (analysis) will also determine $|\chi^{(T)}\rangle$. Now, if the Λ matrix is invertible, from Eq. (1) one can obtain χ by inversion: $|\chi\rangle = \Lambda^{-1} |\chi^{(T)}\rangle$. The invertibility of the Λ matrix, namely $\det \Lambda \neq 0$, depends on the input states $\{\rho^{(i)}\}$ and the noise operations $\chi^{(i)}$ and $\chi^{(f)}$. It may happen that the Λ matrix becomes ill-conditioned [24] for a specific set of input states (for some given noise operations $\chi^{(i)}$ and $\chi^{(f)}$). In such cases, even small errors (whether operational, stochastic, or round-off) in estimation of $\chi^{(T)}$ can be amplified dramatically after multiplication by Λ^{-1} . This in turn may render the estimation of χ (the sought-for unknown map \mathcal{E}) completely unreliable. To minimize the statistical errors, the input states should be chosen such that $\det \Lambda$ is as far from zero as possible. Therefore, the optimal input states $\{\rho_{\text{opt}}^i\}$

[optimal in the sense of minimizing statistical errors] for given $\chi^{(i)}$ and $\chi^{(f)}$ are obtained via maximizing $\det \Lambda$. A similar *faithfulness* measure has already been used in Refs. [7,25]. In Appendix IV, we derive the optimal input states for the case of the ideal DCQD scheme.

III. PROCESS ESTIMATION WITH SPECIFIC NOISY DEVICES

In the following, we describe several examples of widely used incoherent noise models known as depolarizing channels, acting either collectively or separately on systems *A* and *B*. In the simplest case of a depolarizing channel \mathcal{D}_ε acting on a density matrix σ , we have

$$\mathcal{D}_\varepsilon(\sigma) = \varepsilon \sigma + (1 - \varepsilon) \mathbb{1}/\text{Tr}[\mathbb{1}]. \quad (2)$$

That is, with probability ε the state survives the noise; otherwise it becomes completely random. This indicates that we have no knowledge about the result of an error occurring on the state except that it happens with probability $1 - \varepsilon$.

The depolarizing channels are an important class of quantum maps occurring when the coherence in the process vanishes either naturally or via engineered quantum operations [26], and they have been extensively used to describe noise affecting quantum information systems. These channels might naturally emerge as an approximation to the dynamics when the system-bath Hamiltonian contains certain forms of symmetries and fast, random fluctuations. Moreover, the application of random unitaries to symmetrize quantum processes also creates effective depolarizing channels. This method, known as twirling, has been utilized for selective and efficient quantum process tomography [10].

It should be noted that here the depolarizing channel simply serves to illustrate our scheme. The applicability of our approach is thus not restricted to this specific noise model.

A. Depolarizing channels: correlated noise

An important and practically relevant example is the situation in which $\mathcal{E}^{(i)}$ and $\mathcal{E}^{(f)}$ both are two-qubit (hence correlated) depolarizing channels $\mathcal{D}^{[2]}$ [26]

$$\begin{aligned} \rho^{(i)} &\xrightarrow{\mathcal{D}_\varepsilon^{[2]}} \frac{1 - \varepsilon}{4} \mathbb{1} \otimes \mathbb{1} + \varepsilon \rho^{(i)}, \\ P^{jj} &\xrightarrow{\mathcal{D}_{\varepsilon'}^{[2]}} \frac{1 - \varepsilon'}{4} \mathbb{1} \otimes \mathbb{1} + \varepsilon' P^{jj}, \end{aligned}$$

where ε and ε' could be independent of each other or correlated (e.g., $\varepsilon = \varepsilon'$). These errors result in the following noisy data processing of the measurement results of DCQD:

$$\begin{aligned} \text{Tr}[\mathcal{E}(\rho^{(i)}) P^{jj}] &\rightarrow \frac{(1 - \varepsilon)(1 - \varepsilon')}{16} \text{Tr}[\mathcal{E}(\mathbb{1}) \otimes \mathbb{1}] \\ &+ \frac{\varepsilon'(1 - \varepsilon)}{4} \text{Tr}[\mathcal{E}(\mathbb{1}) \otimes \mathbb{1} P^{jj}] + \frac{\varepsilon(1 - \varepsilon')}{4} \\ &\times \text{Tr}[\mathcal{E}(\rho^{(i)})] + \varepsilon \varepsilon' \text{Tr}[\mathcal{E}(\rho^{(i)}) P^{jj}]. \quad (3) \end{aligned}$$

For the Hamiltonian identification task [27,28], $\mathcal{E}(\rho) = e^{-iHt} \rho e^{iHt}$ (which is unital, $\mathcal{E}(\mathbb{1}) = \mathbb{1}$, and trace-preserving,

$\text{Tr}[\mathcal{E}(\rho)] = 1$), we obtain

$$\text{Tr}[\mathcal{E}(\rho^{(i)})P^{jj}] \rightarrow \varepsilon\varepsilon'\text{Tr}[\mathcal{E}(\rho^{(i)})P^{jj}] + (1 - \varepsilon\varepsilon')/4. \quad (4)$$

This relation provides a simple connection between the ideal and the noisy data-processing rules. Another feature of Eq. (4) is that it is valid regardless of the values of ε and ε' ($\neq 0$). This implies that, regardless of whether ε and ε' are in the range that makes the noisy BSP and BSM separable [29,30], the simplicity and applicability of (the modified) DCQD remain intact. In other words, entanglement is not an imperative in the DCQD algorithm.

A generalization of this noise model is the case in which the preparations are modified based on a generalized two-qubit depolarizing channel [26]:

$$\rho^{(i)} \xrightarrow{\tilde{\mathcal{D}}_\varepsilon^{[2]}} \frac{1 - \varepsilon}{4} \mathbb{1} \otimes \mathbb{1} + \varepsilon U \rho^{(i)} U^\dagger,$$

in which U is an already known two-qubit unitary operator. To simplify the following discussion, we assume that BSMs are noiseless ($\mathcal{E}^{(i)} = \mathbb{I}$). Finding the explicit form of $\chi^{(i)}$ is straightforward. We use the form

$$\rho = \frac{1}{4} \left(\mathbb{1} \otimes \mathbb{1} + \sum_{m,n=0}^3 r_{mn} \sigma_m \otimes \sigma_n \right),$$

where \sum' denotes the constrained summation in which the case $(m, n) = (0, 0)$ has been excluded. Using the identity $\sigma_k \sigma_l \sigma_k = (-1)^{1-\delta_{kl}} \sigma_l$, we have $\frac{1}{4} \sum_{ab=0}^3 \sigma_a \otimes \sigma_b \rho \sigma_a \otimes \sigma_b = \rho + \frac{3}{4} \mathbb{1} \otimes \mathbb{1}$, or equivalently $\sum_{ab=0}^3 p_{ab} \sigma_a \otimes \sigma_b \rho \sigma_a \otimes \sigma_b = \mathbb{1} \otimes \mathbb{1}$, where $p_{ab} = 1/3$ except for $p_{00} = -1$. In addition, we expand U in the $\{\sigma_m \otimes \sigma_n\}_{mn=0}^3$ basis: $U = \sum_{mn} a_{mn} \sigma_m \otimes \sigma_n$. Altogether, these relations yield

$$\begin{aligned} \tilde{\mathcal{D}}_\varepsilon^{[2]}(\rho) &= \frac{1 - \varepsilon}{4} \sum_{mn} p_{mn} \sigma_m \otimes \sigma_n \rho \sigma_m \otimes \sigma_n \\ &+ \varepsilon \sum_{mn,m'n'} a_{mn} \bar{a}_{m'n'} \sigma_m \otimes \sigma_n \rho \sigma_{m'} \otimes \sigma_{n'}. \end{aligned}$$

Hence, we obtain $\chi_{mmmm}^{(i)} = p_{mn}(1 - \varepsilon)/4 + \varepsilon |a_{mn}|^2$ (the diagonal elements) and $\chi_{mmn'n'}^{(i)} = \varepsilon a_{mn} \bar{a}_{m'n'}$ for $(m, n) \neq (m', n')$ (the off-diagonal elements). In a compact form, the effect of this noise channel can be expressed as follows:

$$\begin{aligned} &\text{Tr}[\mathcal{E}(\rho^{(i)})P^{jj}] \\ &\rightarrow \frac{(1 - \varepsilon)(1 - \varepsilon')}{16} \text{Tr}[\mathcal{E}(\mathbb{1}) \otimes \mathbb{1}] + \frac{\varepsilon'(1 - \varepsilon)}{4} \text{Tr}[\mathcal{E}(\mathbb{1}) \\ &\otimes \mathbb{1} P^{jj}] + \frac{\varepsilon(1 - \varepsilon')}{4} \text{Tr}[\mathcal{E}(U \rho^{(i)} U^\dagger)] \\ &+ \varepsilon\varepsilon' \text{Tr}[\mathcal{E}(U \rho^{(i)} U^\dagger) P^{jj}]. \end{aligned} \quad (5)$$

Under trace-preserving and unitality conditions, the final data processing is thus modified as follows:

$$\text{Tr}[\mathcal{E}(\rho^{(i)})P^{jj}] \rightarrow \varepsilon\varepsilon' \text{Tr}[\mathcal{E}(U \rho^{(i)} U^\dagger) P^{jj}] + \frac{1 - \varepsilon\varepsilon'}{4}. \quad (6)$$

Although this is not as simple as Eq. (4), it retains a considerable simplicity.

B. Depolarizing channels: uncorrelated noise

We assume that the input states and our measurements are diluted by depolarizing channels [29,30] acting *separately* on

the principal and ancilla qubits, that is, $\mathcal{D} \otimes \mathcal{D}$, where \mathcal{D} acts on a general single-qubit state ρ as follows: $\mathcal{D}_\varepsilon(\rho) = [(1 - \varepsilon)/2] \mathbb{1} + \varepsilon \rho$, or equivalently $\mathcal{D}_\varepsilon(\rho) = \sum_{j=0}^3 p_j \sigma_j \rho \sigma_j$, where $p_0 = (1 + 3\varepsilon)/4$, $p_1 = p_2 = p_3 = (1 - \varepsilon)/4$, and positivity and complete positivity of \mathcal{D}_ε require $-1/3 \leq \varepsilon \leq 1$ [31].

As an important case, we specialize the characterization of the diagonal elements χ_{kk} . This is particularly important in Hamiltonian identification tasks [27,28]. It can be easily seen that for Bell states P^{kk} we obtain

$$P^{kk} \xrightarrow{\mathcal{D}_\varepsilon \otimes \mathcal{D}_\varepsilon} \frac{1 - \varepsilon^2}{4} \mathbb{1} \otimes \mathbb{1} + \varepsilon^2 P^{kk}.$$

Thus, to estimate χ_{kk} , the necessary data processing is modified as in Eqs. (3) and (4) by replacing $\varepsilon\varepsilon' \rightarrow (\varepsilon\varepsilon')^2$ and $i \rightarrow 0$ (recall that $\rho^{(0)} = |\Phi^+\rangle\langle\Phi^+|$). Here, we have assumed that the input (measurement) depolarizing parameter is ε (ε'). This result implies that to estimate the diagonal elements χ_{kk} , whether under correlated noise or uncorrelated noise, the DCQD scheme is robust and classical data processing is modified in a simple fashion. This has immediate applications to the task of Hamiltonian identification [27].

C. Generalized depolarizing channels

Here, we assume that the input states and/or measurements are diluted such that they effectively lead to (known) Bell-diagonal input states and/or Bell-diagonal measurements. Thus, we obtain

$$\begin{aligned} \rho^{(i)} &\xrightarrow{\mathcal{B}_\varepsilon} \sum_{i'=0}^3 \varepsilon_{i'i'} \rho^{(i')}, \\ P^{jj} &\xrightarrow{\mathcal{B}'_\varepsilon} \sum_{j'=0}^3 \varepsilon'_{j'j} P^{j'j'}. \end{aligned}$$

This noise results in the following noisy data processing of the measurement results of DCQD:

$$\text{Tr}[\mathcal{E}(\rho^{(i)})P^{jj}] \rightarrow \sum_{i'j'} \varepsilon_{i'i'} \varepsilon'_{j'j} \text{Tr}[\mathcal{E}(\rho^{(i')})P^{j'j'}]. \quad (7)$$

That is, every measurement result of the new setting is a linear combination of the ideal results. If we define the vector $|\mathbf{p}\rangle = (\mathbf{p}_{ij})^T$, where $\mathbf{p}_{ij} = \text{Tr}[\mathcal{E}(\rho^{(i)})P^{jj}]$, namely

$$|\mathbf{p}\rangle = (\text{Tr}[\mathcal{E}(\rho^{(0)})P^{00}], \text{Tr}[\mathcal{E}(\rho^{(0)})P^{11}], \dots, \text{Tr}[\mathcal{E}(\rho^{(3)})P^{33}])^T$$

and the matrix $\mathbf{A}_{ij,i'j'} = \varepsilon_{i'i'} \varepsilon'_{j'j}$, then Eq. (7) can be written as the following linear matrix transformation (see Appendix A):

$$|\mathbf{p}\rangle \rightarrow \mathbf{A}|\mathbf{p}\rangle. \quad (8)$$

If we arrange the output elements as in Table I, we have

$$|\tilde{\mathbf{p}}\rangle = \mathbf{C}|\mathbf{p}\rangle, \quad (9)$$

where \mathbf{C} is the (constant) coefficient matrix; hence $|\tilde{\mathbf{p}}\rangle \rightarrow \mathbf{AC}^{-1}|\tilde{\mathbf{p}}\rangle$.

IV. SUMMARY

We have provided a scheme for utilizing auxiliary quantum correlations to perform process estimation tasks with faulty quantum operations. We have demonstrated our approach via generalizing the ideal scheme of DCQD, where the required preparations and measurements could be noisy. It has been shown that when the systematic faulty operations are of the form of depolarizing channels, the overhead data processing is

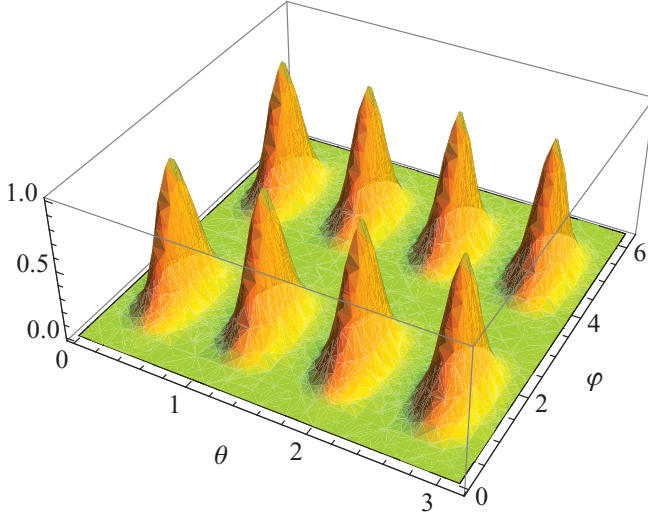

FIG. 2. (Color online) Value of $|\det \mathbf{A}|$ vs θ and φ . Here, the coefficient matrix $\mathbf{A}(\theta, \varphi)$ relates the experimental outcomes to the unknown elements of the superoperator $|\chi^{(T)}\rangle = \mathbf{A}|\chi\rangle$. The input states for the standard DCQD, as defined in Table I, for example, $|\Phi_{\alpha}^{\pm}\rangle = \alpha|00\rangle + \beta|11\rangle$, are parameterized as $\alpha = \cos\theta$ and $\beta = e^{i\varphi}\sin\theta$ ($\varphi \neq k\pi$, $k \in \mathbb{Z}$). The optimal input states are associated to those parameters for which $|\det \mathbf{A}|$ has its maximal value 1, leading to a minimal statistical error.

the results of the measurements can be related to the χ_{mn} elements in a more straightforward fashion. Here, the constant coefficient matrix (\mathbf{C}) relates the results of the new BSMs ($\tilde{\mathbf{p}}$) to those of the conventional BSMs (\mathbf{p}).

APPENDIX B: OPTIMAL INPUT STATES FOR THE IDEAL (NOISELESS) DCQD

Here, we find the optimal input states for the ideal DCQD. The idea is to choose the input states such that the (linear) inversion on the experimental data (to read out χ matrix elements) can be performed reliably. That is, the goal should be to make the coefficient matrix as far from singular matrices as possible. Maximizing the determinant of this matrix is a sufficient condition to guarantee its reliable invertibility and hence in turn minimal error propagation.

The data obtained from the measurements (BSMs) are $\text{Tr}[\mathcal{E}(\rho^{(i)})P^{jj}]$, where $\{\rho^{(i)}\}$ corresponds to the first column of Table I, respectively, for $i = 0, 1, 2, 3$. We parameterize the input states as $\alpha = \cos\theta$ and $\beta = e^{i\varphi}\sin\theta$ ($\varphi \neq k\pi$, $k \in \mathbb{Z}$). Using Eq. (10), one can express Eq. (1), for the standard DCQD [4], as the following:

$$\begin{pmatrix} \text{Tr}[P^{00}\mathcal{E}(\rho^{(1)})] \\ \text{Tr}[P^{11}\mathcal{E}(\rho^{(1)})] \\ \text{Tr}[P^{22}\mathcal{E}(\rho^{(1)})] \\ \text{Tr}[P^{33}\mathcal{E}(\rho^{(1)})] \\ \text{Tr}[P^{00}\mathcal{E}(\rho^{(2)})] + \text{Tr}[P^{33}\mathcal{E}(\rho^{(2)})] \\ \text{Tr}[P^{11}\mathcal{E}(\rho^{(2)})] + \text{Tr}[P^{22}\mathcal{E}(\rho^{(2)})] \\ \text{Tr}[P^{00}\mathcal{E}(\rho^{(2)})] - \text{Tr}[P^{33}\mathcal{E}(\rho^{(2)})] \\ \text{Tr}[P^{11}\mathcal{E}(\rho^{(2)})] - \text{Tr}[P^{22}\mathcal{E}(\rho^{(2)})] \\ \text{Tr}[P^{00}\mathcal{E}(\rho^{(3)})] + \text{Tr}[P^{11}\mathcal{E}(\rho^{(3)})] \\ \text{Tr}[P^{22}\mathcal{E}(\rho^{(3)})] + \text{Tr}[P^{33}\mathcal{E}(\rho^{(3)})] \\ \text{Tr}[P^{00}\mathcal{E}(\rho^{(3)})] - \text{Tr}[P^{11}\mathcal{E}(\rho^{(3)})] \\ \text{Tr}[P^{33}\mathcal{E}(\rho^{(3)})] - \text{Tr}[P^{22}\mathcal{E}(\rho^{(3)})] \\ \text{Tr}[P^{00}\mathcal{E}(\rho^{(4)})] + \text{Tr}[P^{22}\mathcal{E}(\rho^{(4)})] \\ \text{Tr}[P^{11}\mathcal{E}(\rho^{(4)})] + \text{Tr}[P^{33}\mathcal{E}(\rho^{(4)})] \\ \text{Tr}[P^{00}\mathcal{E}(\rho^{(4)})] - \text{Tr}[P^{22}\mathcal{E}(\rho^{(4)})] \\ \text{Tr}[P^{33}\mathcal{E}(\rho^{(4)})] - \text{Tr}[P^{11}\mathcal{E}(\rho^{(4)})] \end{pmatrix} = \begin{pmatrix} 1 & 0 & 0 & 0 & 0 & 0 & 0 & 0 & 0 & 0 & 0 & 0 & 0 & 0 & 0 \\ 0 & 0 & 0 & 0 & 0 & 1 & 0 & 0 & 0 & 0 & 0 & 0 & 0 & 0 & 0 \\ 0 & 0 & 0 & 0 & 0 & 0 & 0 & 0 & 0 & 0 & 1 & 0 & 0 & 0 & 0 \\ 0 & 0 & 0 & 0 & 0 & 0 & 0 & 0 & 0 & 0 & 0 & 0 & 0 & 0 & 1 \\ 1 & 0 & 0 & x & 0 & 0 & 0 & 0 & 0 & 0 & 0 & 0 & x & 0 & 0 \\ 0 & 0 & 0 & 0 & 0 & 1 & -ix & 0 & 0 & ix & 1 & 0 & 0 & 0 & 0 \\ z & 0 & 0 & iy & 0 & 0 & 0 & 0 & 0 & 0 & 0 & 0 & -iy & 0 & 0 \\ 0 & 0 & 0 & 0 & 0 & z & y & 0 & 0 & y & -z & 0 & 0 & 0 & 0 \\ 1 & x & 0 & 0 & x & 1 & 0 & 0 & 0 & 0 & 0 & 0 & 0 & 0 & 0 \\ 0 & 0 & 0 & 0 & 0 & 0 & 0 & 0 & 0 & 0 & 1 & -ix & 0 & 0 & ix \\ z & iy & 0 & 0 & -iy & -z & 0 & 0 & 0 & 0 & 0 & 0 & 0 & 0 & 0 \\ 0 & 0 & 0 & 0 & 0 & 0 & 0 & 0 & 0 & 0 & z & y & 0 & 0 & y \\ 1 & 0 & -x & 0 & 0 & 0 & 0 & -ix & 0 & 0 & 0 & 0 & ix & 0 & 1 \\ 0 & 0 & 0 & 0 & 0 & 0 & 0 & 0 & -x & 0 & 1 & 0 & 0 & 0 & 0 \\ -z & 0 & iy & 0 & 0 & 0 & 0 & 0 & 0 & -iy & 0 & z & 0 & 0 & 0 \end{pmatrix} \begin{pmatrix} \chi_{00} \\ \chi_{01} \\ \chi_{02} \\ \chi_{03} \\ \chi_{10} \\ \chi_{11} \\ \chi_{12} \\ \chi_{13} \\ \chi_{20} \\ \chi_{21} \\ \chi_{22} \\ \chi_{23} \\ \chi_{30} \\ \chi_{31} \\ \chi_{32} \\ \chi_{33} \end{pmatrix},$$

where in the coefficient matrix $\mathbf{A}(\theta, \varphi)$ we have $x = \cos 2\theta$, $y = \sin 2\theta \sin \varphi$, and $z = \sin 2\theta \cos \varphi$. The determinant of this matrix is obtained as

$$|\det \mathbf{A}| = \sin^6 4\theta \sin^6 \varphi,$$

which attains its maximum value 1 at $(\theta = \pi/8 + k\pi/4, \varphi = \pi/2 + k'\pi)$, $\forall k, k' \in \mathbb{Z}$ (Fig. 2). Therefore, the optimal input

states $\{\rho^{(i)}\}$ for the standard DCQD are as in Table I, in which μ and ν are either of the pairs calculated from the maximal set of θ and φ . A simple calculation shows that the amount of entanglement (exactly speaking, concurrence [32]) of the optimal nonmaximally entangled input states is $1/\sqrt{2}$ (independent of φ).

- [1] M. Paris and J. Rehaček (Eds.), *Quantum State Estimation*, Lecture Notes in Physics, Vol. 649 (Springer-Verlag, Berlin, 2004).
- [2] M. A. Nielsen and I. L. Chuang, *Quantum Computation and Quantum Information* (Cambridge University Press, Cambridge, UK, 2000).
- [3] D. W. Leung, Ph.D. thesis, Stanford University, 2000; G. M. D'Ariano and P. Lo Presti, Phys. Rev. Lett. **86**, 4195 (2001).
- [4] M. Mohseni and D. A. Lidar, Phys. Rev. Lett. **97**, 170501 (2006).
- [5] A. Shabani, R. L. Kosut, and H. Rabitz, e-print arXiv:0910.5498.
- [6] M. Lobino, D. Korystov, C. Kupchak, E. Figueroa, B. C. Sanders, and A. I. Lvovsky, Science **322**, 563 (2008).
- [7] J. B. Altepeter, D. Branning, E. Jeffrey, T. C. Wei, P. G. Kwiat, R. T. Thew, J. L. O'Brien, M. A. Nielsen, and A. G. White, Phys. Rev. Lett. **90**, 193601 (2003).
- [8] M. Mohseni and D. A. Lidar, Phys. Rev. A **75**, 062331 (2007).
- [9] Z.-W. Wang, Y.-S. Zhang, Y.-F. Huang, X.-F. Ren, and G.-C. Guo, Phys. Rev. A **75**, 044304 (2007); W. T. Liu, W. Wu, P.-X. Chen, C.-Z. Li, and J.-M. Yuan, *ibid.* **77**, 032328 (2008).
- [10] A. Bendersky, F. Pastawski, and J. P. Paz, Phys. Rev. Lett. **100**, 190403 (2008); J. Emerson, M. Silva, O. Moussa, C. Ryan, M. Laforest, J. Baugh, D. G. Cory, and R. Laflamme, Science **317**, 1893 (2007).
- [11] G. M. D'Ariano, Phys. Lett. **A300**, 1 (2002).
- [12] M. Mohseni, A. T. Rezakhani, and D. A. Lidar, Phys. Rev. A **77**, 032322 (2008).
- [13] A. E. Allahverdyan, R. Balian, and T. M. Nieuwenhuizen, Phys. Rev. Lett. **92**, 120402 (2004).
- [14] V. V. Shende, I. L. Markov, and S. S. Bullock, Phys. Rev. A **69**, 062321 (2004).
- [15] L. M. K. Vandersypen and I. L. Chuang, Rev. Mod. Phys. **76**, 1037 (2004).
- [16] J. M. Raimond, M. Brune, and S. Haroche, Rev. Mod. Phys. **73**, 565 (2001).
- [17] H. Häffner, C. F. Roos, and R. Blatt, Phys. Rep. **469**, 155 (2008).
- [18] J. T. Barreiro, N. K. Langford, N. A. Peters, and P. G. Kwiat, Phys. Rev. Lett. **95**, 260501 (2005); P. Kok, W. J. Munro, K. Nemoto, T. C. Ralph, J. P. Dowling, and G. J. Milburn, Rev. Mod. Phys. **79**, 135 (2007).
- [19] J. E. Sharping, M. Fiorentino, and P. Kumar, Opt. Lett. **26**, 367 (2001); J. Fan, M. D. Eisaman, and A. Migdall, Phys. Rev. A **76**, 043836 (2007).
- [20] J. R. Petta, A. C. Johnson, J. M. Taylor, E. A. Laird, A. Yacoby, M. D. Lukin, C. M. Marcus, M. P. Hanson, and A. C. Gossard, Science **309**, 2180 (2005).
- [21] J. Q. You and F. Nori, Phys. Today **58**, 42 (2005).
- [22] M. Cho, H. M. Vaswani, T. Brixner, J. Stenger, and G. R. Fleming, J. Phys. Chem. B **109**, 10542 (2005); M. Mohseni, P. Rebentrost, S. Lloyd, and A. Aspuru-Guzik, J. Chem. Phys. **129**, 174106 (2008); M. Sarovar, A. Ishizaki, G. R. Fleming, and B. Whaley, e-print arXiv:0905.3787.
- [23] M. M. Wolf and J. I. Cirac, Commun. Math. Phys. **279**, 147 (2008).
- [24] C. D. Meyer, *Matrix Analysis and Applied Linear Algebra* (Society for Industrial and Applied Mathematics, Philadelphia, PA, 2000).
- [25] G. M. D'Ariano and P. Lo Presti, Phys. Rev. Lett. **91**, 047902 (2003).
- [26] H.-J. Briegel, W. Dür, J. I. Cirac, and P. Zoller, Phys. Rev. Lett. **81**, 5932 (1998); W. Dür, H.-J. Briegel, J. I. Cirac, and P. Zoller, Phys. Rev. A **59**, 169 (1999); B. M. Terhal, I. L. Chuang, D. P. DiVincenzo, M. Grassl, and J. A. Smolin, *ibid.* **60**, 881 (1999).
- [27] M. Mohseni, A. T. Rezakhani, and A. Aspuru-Guzik, Phys. Rev. A **77**, 042320 (2008).
- [28] M. Mohseni and A. T. Rezakhani, Phys. Rev. A **80**, 010101(R) (2009).
- [29] S. L. Braunstein, C. M. Caves, R. Jozsa, N. Linden, S. Popescu, and R. Schack, Phys. Rev. Lett. **83**, 1054 (1999).
- [30] B. M. Terhal and K. G. Vollbrecht, Phys. Rev. Lett. **85**, 2625 (2000).
- [31] C. King and M. B. Ruskai, IEEE Trans. Info. Theory **47**, 192 (2001).
- [32] W. K. Wootters, Phys. Rev. Lett. **80**, 2245 (1998).