

# New Results on Single-Photon Up-Conversion

Aaron P. VanDevender and Paul G. Kwiat

University of Illinois, 1110 W Green St., Urbana, IL, USA

## ABSTRACT

The process of up-conversion is shown to enable superior single-photon detectors in the infrared, compared to InGaAs and germanium Avalanche Photodiodes (APDs) (normally used for IR single photon detection). After up-converting an infrared photon to a visible one in a non-linear crystal—Periodically Poled Lithium Niobate (PPLN)—we use a silicon APD to efficiently detect the frequency up-shifted IR photon. We have demonstrated this process at the “high-intensity” level and at the single-photon level, where the up-converted state is effectively a superposition of the single photon Fock state and the vacuum state. We achieve an 80% conversion efficiency over the width of the pulse, and show that this process is *coherent*, a necessary ingredient for many applications.

**Keywords:** Quantum Information, Quantum Cryptography, Single Photon Detection, Up-Conversion

## 1. INTRODUCTION

Recently the field of quantum cryptography<sup>1,2,3</sup> has arisen to address the problem of securely sending secret messages between two participants. The BB84 protocol<sup>4</sup> was introduced by Charles Bennett and Gilles Brassard as a technique for sending data in a provably secure fashion using quantum bits. Other protocols have emerged, such as BB92<sup>5</sup> and SSP,<sup>6</sup> which are variations on the basic idea introduced by Bennett and Brassard and make various trade-offs. However, all of the protocols depend on the ability to faithfully send quantum states between the two parties. Since no information travels faster than light, and photons are easily and precisely produced in well-defined quantum states, they are the natural choice for quantum communication applications. Moreover, one is led to the use of infrared (IR) photons (e.g., at 1550-nm), as this is the wavelength region corresponding to the optimal transparency of our fiber optics infrastructure. Unfortunately, one drawback of using IR photons is that they are difficult to detect. Most infrared single photon detectors have very low quantum efficiency and very high dark counts. The process of high-efficiency up-conversion, however, can provide a means to detect these IR photons with much higher efficiency, thereby improving such applications as quantum key distribution<sup>7,8,9</sup>.

In addition to quantum cryptography, other applications would also benefit from the ability to efficiently detect single photons in the infrared. Linear-optics quantum computation is a technique whereby single and entangled photons are operated on with standard linear optics (e.g., mirrors and beam-splitters); together with a post-selection step, arbitrary unitary operations can be performed on large quantum states.<sup>10</sup> However, for this technique to be able to efficiently compute operations on more than one qubit, very efficient detectors are required. Classical communications would also benefit from the ability to faithfully detect single photons in the IR, since the distance over which such communications can take place is limited by the attenuation in the fiber (a constant) and the power of the light source used to send the signal. While this power can be increased, this is sometimes difficult, especially if the transmitter has limited power consumption constraints. However, by lowering the threshold of detection, e.g., to the single photon level, one could use longer fibers with the same laser power and still tolerate the additional attenuation.<sup>11</sup> Finally, two other applications which would benefit from better detection of single photons in the infrared are IR astronomy<sup>12,13,14</sup> and detection of single molecules and atoms which have transitions in the IR.<sup>15,16</sup>

Detecting single photons, however, is not the only reason for wanting to investigate frequency up-conversion. As various methods of quantum computing mature (e.g., bulk spin resonance, trapped ions, SQUID-based quantum computing devices) it will likely be desirable to “network” such quantum computers together to maximize

---

Further author information: (Send correspondence to Aaron VanDevender)

A. P. VanDevender: E-mail: vandvndr@uiuc.edu, Telephone: 1 217 244 1608

P. G. Kwiat: E-mail: kwiat@uiuc.edu, Telephone: 1 217 333 9116

the complexity of possible quantum computations. To accomplish this, we will need a means of transmitting quantum bits from one quantum system to another even when the two systems themselves are quite different. High-efficiency up-conversion can be used to coherently convert photons created by one quantum computing system to a wavelength appropriate for a different system, thus allowing transmission of qubits from one machine to another.

The conversion of photons from one wavelength to another, can be performed using the process of up-conversion, whereby an input photon at IR wavelengths (e.g., 1550 nm) is combined with an intense “escort” beam (e.g., at 1064 nm) inside of a nonlinear crystal to produce an output photon (e.g., at 631 nm) which has a frequency equal to the sum of the input and escort frequencies (to conserve energy). Efficient detection of the input photon is then enabled by detecting the output photon after the conversion using a silicon Avalanche Photodiode (APD). The silicon APD has a much higher detection efficiency at the visible output wavelength than do single photon detectors used to measure photons at the IR input wavelength. After discussing basic properties of nonlinear optical materials and phase-matching considerations in Section 2, we will explain how to produce both high efficiency up-conversion (Section 3), as well as over-conversion, where the input photon is converted to the output wavelength and back to the input wavelength (Section 4). Also, we will discuss recent experiments demonstrating the coherence of the process (Section 5).

## 2. THE PROCESS OF UP-CONVERSION

In systems constructed with linear optics such as prisms, beam-splitters, and lenses, the amount of light at any output port is always proportional to the input light. Certain materials, however, display a nonlinear response to applied optical fields. Some of the most common nonlinear materials are known as  $\chi^{(2)}$  materials ( $\chi$  is the dielectric susceptibility of the material), in which the spontaneous polarization has a term that is proportional to the square of the applied field. We can then use this property to couple different frequency modes of light together. The equations which describe this coupling can be reduced to (Myers *et al.*<sup>17</sup>):

$$\frac{dE_i}{dz} = i \frac{\omega_i d_Q}{n_i c} E_o E_e^* \quad (1)$$

$$\frac{dE_o}{dz} = i \frac{\omega_o d_Q}{n_o c} E_i E_e, \quad (2)$$

assuming that the input and output beams are weak compared to the escort beam ( $E_e \gg E_i, E_o$ ; depletion regime), and that the phase mismatch equals 0. The phase mismatch is given by:

$$\Delta k_Q \equiv k_o - k_i - k_e - \frac{2\pi}{\Lambda} = 0. \quad (3)$$

Solving for  $E_o$  under the initial condition  $E_o(z=0) = 0$ , we find a sinusoidal oscillation for the output field amplitude, which we can then convert to a probability of up-conversion  $P_o(z)$ :

$$P_o(z) \propto \sin^2 \left( A \sqrt{I_e} z \right), \quad (4)$$

where  $A$  is a constant.

## 3. HIGH EFFICIENCY

In our experiment (Figure 1), we used a 45-mm long multi-grating PPLN crystal [HC Photonics] to perform the up-conversion of a 1550-nm input photon and a 1064-nm escort beam, produced in a Nd:YAG laser.<sup>18</sup> The two beams are combined using a dichroic beam-splitter, and then they are focused on the nonlinear crystal, which is heated to 95°C, the temperature at which the phase-matching condition is optimal. The resulting output is then filtered through a set of interference filters, prisms and irises to eliminate the remaining 1064-nm light, as well as some 532-nm light which is created through a parasitic second-harmonic generation process in the nonlinear crystal. Finally, the up-converted photon reaches a silicon APD and is detected.

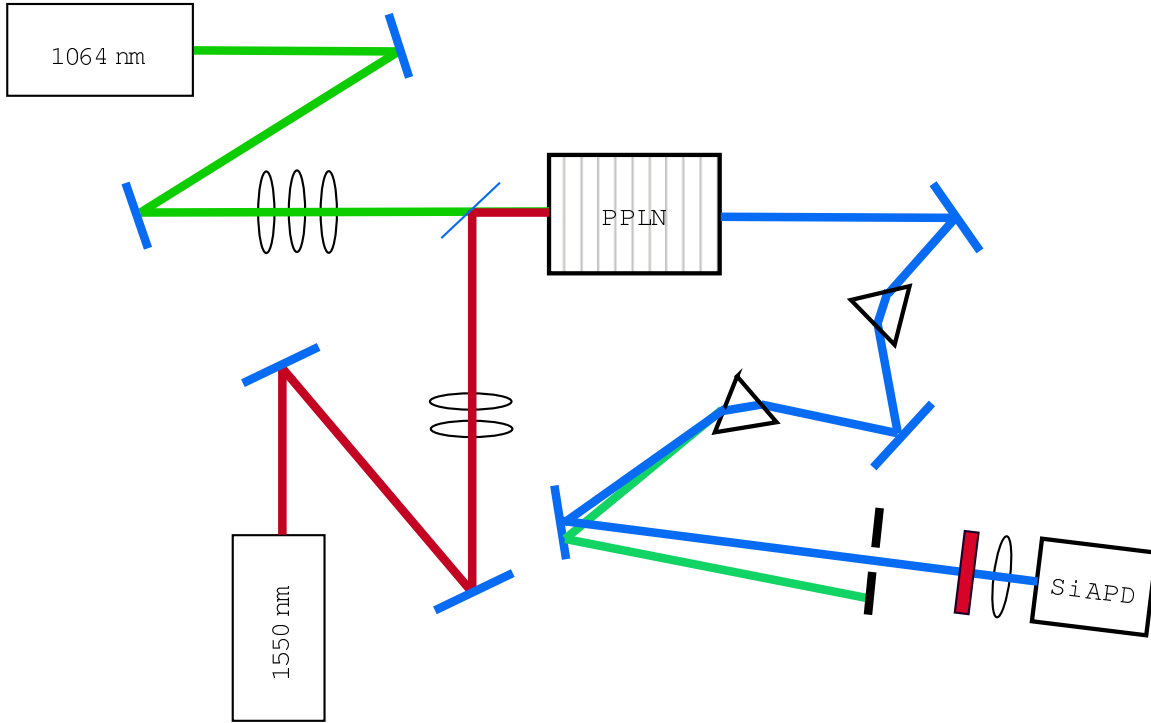

**Figure 1.** A schematic of the basic up-conversion experiment showing the PPLN up-conversion crystal, the 1550-nm input beam, the 1064-nm escort beam, the resulting 631-nm beam, and the APD.

Our Nd:YAG laser outputs 50 mW of average power in 600-ps long pulses. The pulse rate is 7.2 kHz, and each pulse has about  $6\mu\text{J}$  of energy. Since these pulses are not square, but are roughly Gaussian in shape, in order to calculate the expected efficiency of conversion over the full-width half-maximum of the pulse, we need to apply the conversion formula (Equation 4) to the shape of the escort pulse, which we have measured using a fast silicon photodiode (Figure 2a). This yields the conversion profile (conversion efficiency as a function of time; Figure 2b)—which, when averaged over the width of the pulse, gives the total conversion probability.

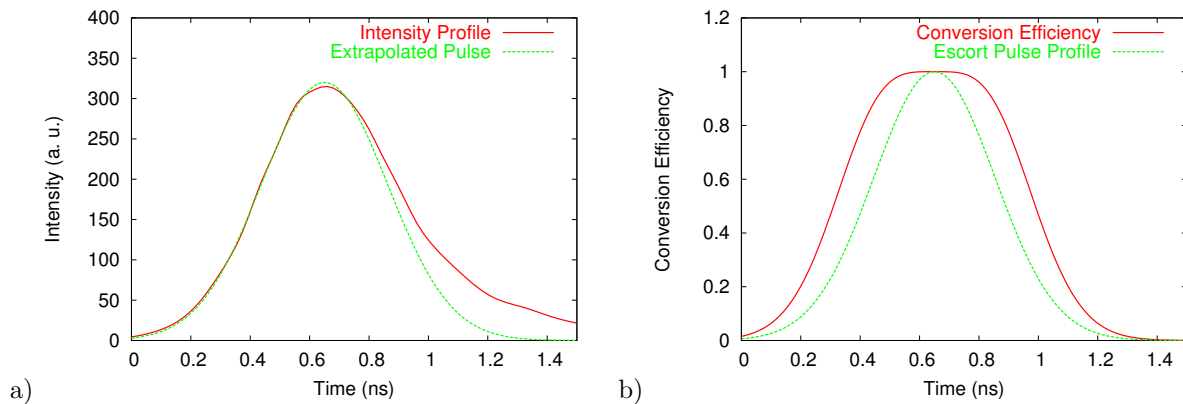

**Figure 2.** a) Intensity profile of the escort laser as measured with a fast photodiode (red), and Gaussian fit (green). b) Intensity profile of the escort laser (green), and the calculated conversion efficiency profile (red).

Once we know the conversion profile, we can calculate the peak conversion efficiency. Since our technique

for detecting single photons depends on the up-conversion process being of near unit efficiency, we have made measurements showing that the output state of the conversion process is a linear mapping of the input state onto a different wavelength, and that the ratio of that mapping is close to one. For this experiment we used a CW 1550-nm source, at varying levels of intensity. For the high intensity, a silicon power meter was used to measure the intensity of output light. For the low intensity case, where the average number of 1550-nm photons per escort pulse is less than 1, we used a silicon APD.

#### 4. OVERCONVERSION

The evolution described by Equation 4 is analogous to a Rabi oscillation between the input and output states, mediated by the strength of the escort field. The spatial period  $L_c$  for this process is

$$L_c = \sqrt{\frac{\pi^2 n_i n_o c^2}{\omega_i \omega_o d_Q^2 |E_e|^2}}. \quad (5)$$

For a crystal of length  $L_c$  (where  $L_c$  implicitly depends on the escort intensity), the input light will be completely up-converted to the output frequency, and then down-converted back to the original input frequency before leaving the crystal. For a given crystal length  $L$ , by choosing the escort intensity to give  $L_c = 2L$ , we can achieve very high conversion efficiency from  $\omega_i$  to  $\omega_o$ . Note that by varying the escort power, we can also prepare photons in arbitrary superpositions of the “input” and “output” frequencies. Such non-degenerate states may be important in future quantum information applications.<sup>19</sup>

While observing a complete Rabi oscillation as a function of escort intensity remains a future goal, we have performed a similar experiment which gives preliminary results on this phenomenon of over-conversion. An electro-optic modulator (EOM) was used to create short, 200-ps input pulses at 1550 nm, which were combined with the escort laser in the nonlinear crystal. We then let the relative position of the input and escort pulses vary randomly. By measuring both the position of the input pulse with respect to the escort pulse, and the probability of up-conversion, we observed a region of the escort pulse where the intensity was great enough to convert the input pulse to the output frequency, and then partially back again. The results of this experiment, as well as the theoretical prediction of the over-conversion are shown in Figure 3. The discrepancy between the results and the prediction is probably due to an inability to accurately characterize the profile of the escort and input beams. Since the conversion probability strongly depends on the intensity of the escort and input pulse shapes, small non-Gaussian variations in the pulse shapes may cause a deviation in the conversion profile.

#### 5. COHERENT UP-CONVERSION

In order for this technique to be useful in transmitting qubits, i.e., from one quantum computer to another, it is not enough that it merely be efficient. This process must also be *coherent*. Any phase information present in the input state must also be transferred to the output state. We have demonstrated this by observing interference fringes in the output state, as the phase of the input state is varied. The experiment uses two interferometers, folded on top of each other for stability (see Figure 4). Each interferometer has a long path and a short path. The difference in paths is  $\approx 3$  ns, which is longer than the input and escort pulses, so there can be no interference between the two paths at the output of the first interferometer; it is also longer than the  $\tilde{1}$ -ns resolution of the Si APD. Both pulses then are up-converted inside of our PPLN crystal, and the output photons are sent through a second interferometer (here we reuse the first interferometer). Since it has identical long and short paths, a pulse which took the short path in the first interferometer and the long path in the second will arrive at the output of the second interferometer at the same time as a pulse that took the long path in the first interferometer and the short path in the second. If the up-conversion process has preserved the phase information of the photons, the long-short process will interfere with the short-long process at the exit port. By tilting a flat, dispersive piece of glass in the long arm of our interferometer, we can change the phase of the long-short path with respect to the short-long path. Thus by varying the tilt angle of the glass, we can change the interference condition in the exit port and observe fringes. Preliminary experimental output of the interferometer is shown in Figure 5. We have obtained a maximum fringe visibility of  $71 \pm 3\%$  using this technique, though thus far only in the high intensity regime. We are currently making progress on observing interference at the single photon level.

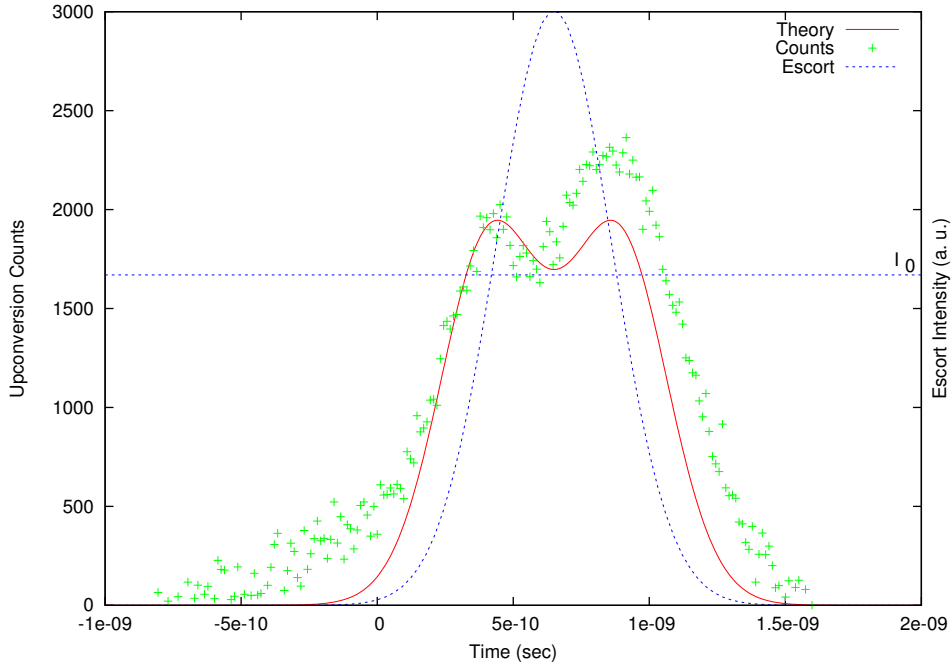

**Figure 3.** Measured conversion profile (green) and predicted profile (red) for an escort beam (blue) which has a peak intensity above  $I_0$ , the escort intensity required for maximum conversion probability. Portions of the input beam which overlap the region of the escort above  $I_0$  are converted completely to the output state, and then partially back to the input state. This causes the dip that is visible in the center of the conversion profile.

## 6. CONCLUSION

High-efficiency up-conversion has the potential to enhance or enable many fields of study, such as quantum computing, quantum cryptography, long distance telecommunications, molecular and atomic physics, and IR astronomy. It can also assist in areas of more theoretical interest in quantum information, by giving access to larger Hilbert spaces of photons, which could enable experiments on dense coding, and bound entangled states. The process is shown to be coherent, as it preserves the phase relationships and produces fringes. Further research may show that it also preserves entanglement, which would provide the basis a quantum network. We have also shown that over-conversion is possible which could allow single photons to hold extra qubits, in addition to the polarization qubit. Our next plans involve extending this system to enable up-conversion of arbitrary polarization states, using two coherently driven crystals.<sup>20</sup> This would enable quantum state transduction of general polarization qubits. Finally, we will explore the up-conversion of photons that are themselves members of an entangled pair. Such capabilities may play a critical role, e.g., in devices such as quantum repeaters<sup>21</sup> to enable long distance quantum communication.

## ACKNOWLEDGMENTS

This work was supported by the MURI Center for Photonic Quantum Information Systems (ARO/ARDA program DAAD19-03-1-0199). Additional funding for this research was provided by the DCI postdoctoral program. We would like to thank Richard Hughes and company of Los Alamos National Laboratory and ARDA for their assistance in conducting this research, as well as thank Franco Wong and Marius Albota from MIT for helpful discussions.

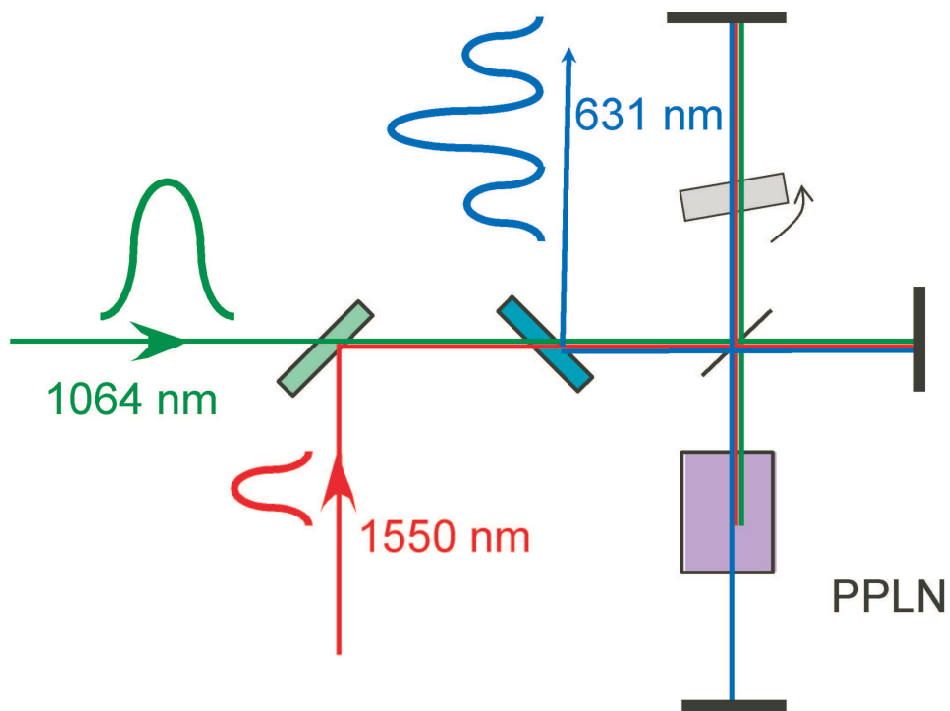

**Figure 4.** Schematic of up-conversion coherence experiment. After the input and escort pulses are combined, they pass through either a long arm or a short arm before being up-converted. The up-converted pulse then also travels through either a long arm or a short arm, giving four possible paths to traverse the setup. Interference is observed between the short-long and long-short processes.

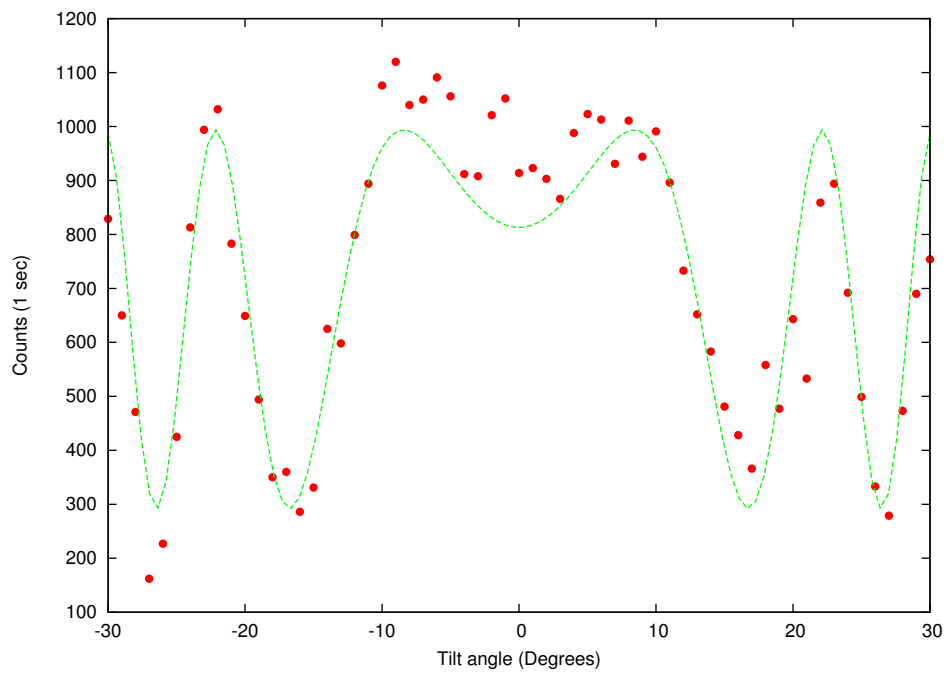

**Figure 5.** Fringe data for interferometer as a function of the tilt angle of the glass, and  $71 \pm 3\%$  visibility fit. Timing information was used to eliminate photons which took the short-short and long-long paths.

## REFERENCES

1. N. Gisin, G. Ribordy, W. Tittel, and H. Zbinden, "Quantum cryptography," *Rev. Mod. Phys.* **74**, p. 145, 2002.
2. M. B. *et al.*, "Experimental long wavelength quantum cryptography: From single-photon transmission to key extraction protocols," *J. Mod. Opt.* **47**, pp. 563–579, 2000.
3. R. J. H. *et al.*, "Quantum cryptography for secure satellite communications," in *2000 IEEE Aerospace Conference, IEEE Aerosp. Conf. Proc.* **1**, pp. 191–200, 2000.
4. C. H. Bennett and G. Brassard, "Quantum cryptography: Public key distribution and coin tossing," in *Proceedings of IEEE International Conference on Computers, Systems and Signal Processing*, 1984.
5. C. H. Bennett, "Quantum cryptography using any two nonorthogonal states," *Phys. Rev. Lett.* **68**, p. 3121, 1992.
6. H. Bechmann-Pasquinucci and N. Gisin, "Incoherent and coherent eavesdropping in the six-state protocol of quantum cryptography," *Phys. Rev. A* **59**, pp. 4238–48, 1999.
7. S. N. Molotkov and S. S. Nazin, "Is there a fundamental limit on the length of a communication channel in a single-photon quantum cryptosystem?," *JETP Lett.* **64**, pp. 866–9, 1996.
8. N. Lütkenhaus, "Security against individual attacks for realistic quantum key distribution," *Phys. Rev. B.* **61**, p. 052304, 2000.
9. E. Waks, C. Santori, and Y. Yamamoto, "Security aspects of quantum key distribution with sub-Poisson light," *Phys. Rev. A* **66**, p. 042315, 2002.
10. E. Knill, R. Laflamme, and G. J. Milburn, "A scheme for efficient quantum computation with linear optics," *Nature* **409**, pp. 46–52, 2001.
11. A. K. *et al.*, "Single-photon counter for long-haul telecom," *IEEE Circuits and Devices Magazine* **15**, pp. 34–40, 1999.
12. R. W. Boyd and C. H. Townes, "An infrared upconverter for astronomical imaging," *Appl. Phys. Lett.* **31**, p. 440, 1977.
13. E. C. Cheung, K. Koch, and G. T. Moore, "Frequency upconversion by phase-matched sum-frequency generation in an optical parametric oscillator," *Opt. Lett.* **23**, pp. 1967–1969, 1994.
14. M. Poulain, "Fluoride glass fibers: applications and prospects," in *Infrared Glass Optical Fibers and Their Applications, Proc. SPIE* **3416**, pp. 2–12, 1998.
15. S. A. Soper, "Single-molecule detection in the near-ir using continuous-wave diode laser excitation with an avalanche photon detector," *Appl. Spectroscopy* **52**, pp. 1–6, 1998.
16. A. Castro and E. B. Shera, "Single-molecule detection: applications to ultrasensitive biochemical analysis," *Appl. Optics* **34**, pp. 3218–22, 1995.
17. L. E. Myers, R. C. Eckardt, M. M. Fejer, R. L. Byer, W. R. Bosenberg, and J. W. Pierce, "Quasi-phase-matched optical parametric oscillators in bulk periodically poled LiNbO<sub>3</sub>," *J. Opt. Soc. Am. B* **12**, pp. 2102–2116, 1995.
18. A. P. VanDevender and P. G. Kwiat, "High-efficiency single photon detection via frequency up-conversion," in *Quantum Information and Computation*, E. Donkor, A. R. Pirich, and H. E. Brandt, eds., *Proc. SPIE* **5105**, pp. 216–224, 2003.
19. G. Giorgi, P. Mataloni, and F. D. Martini, "Frequency hopping in quantum interferometry: Efficient up-down conversion for qubits and ebits," *Phys. Rev. Lett.* **90**, p. 027902, 2003.
20. A. P. VanDevender and P. G. Kwiat, "High efficiency single photon detection via frequency up-conversion," *Journal of Modern Optics* **51**, pp. 1433–45, 2004.
21. L. M. Duan, M. D. Lukin, J. I. Cirac, and P. Zoller, "Long-distance quantum communication with atomic ensembles and linear optics," *Nature* **414**, pp. 413–8, 2001.